

Data Sheet

Pressure regulating valve Type **OFV** and **OFV-SS 20-25**

Designed to prevent fluttering due to low velocity and/or low density

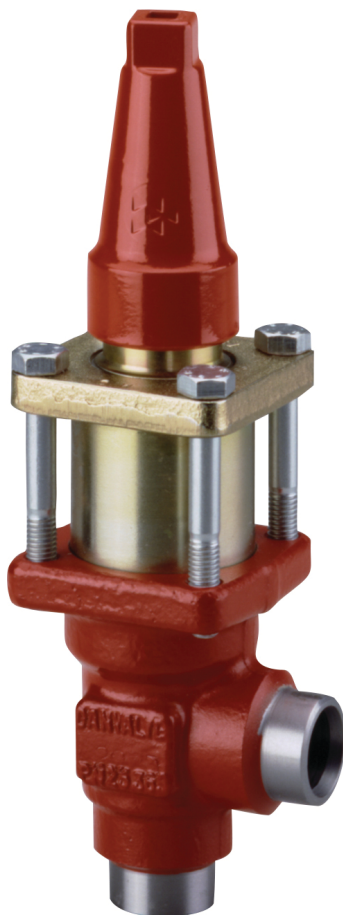

OFV are angle-way pressure regulating valves, which have adjustable opening pressure and cover the differential pressure range (ΔP): 2 - 8 bar (29 - 116 psi). The valve can be closed manually, e.g. during plant service and have backseating, enabling the spindle seal to be replaced with the valve still under pressure.

The valves are especially designed to prevent fluttering due to low velocity and/or low density. In consequence it is possible to apply the valves with wide fluctuations in capacity demands, i.e. from maximum performance to part load. A flexible O-ring provides perfect sealing over the seat.

Features

- Applicable to HCFC, HFC, R717(Ammonia) and R744 (CO₂).
- Full temperature range packing gland -50 °C / +150 °C (-58 °F / +302 °F)
- Maximum operating pressure: 40 bar (580 psig)
- Three functions in one valve. The OFV valve combines the functions of a pressure regulating valve, a check valve and a shut-off valve
- Classification: DNV, CRN, BV, EAC etc. To get an updated list of certification on the products please contact your local Danfoss Sales Company.
- Special features for OFV-SS
 - Low temperature stainless steel housing and bonnet
 - Low temperature packing gland -60 °C / +150 °C (-76 °F / +302 °F)
 - Maximum operating pressure 52 bar (754 psig)

Application

Pressure/temperature control during hot gas defrosting

In order to obtain efficient hot gas defrosting the temperature (pressure) must be increased to approx. 10°C (50°F). The OFV is the optimal solution for controlling the defrosting pressure and thus the corresponding temperature. It is recommended to start the defrosting cycle by closing the ICLX valve in the liquid supply line and allowing some of the cold liquid contained in the evaporator to return to the liquid separator.

Close the ICLX valve in the suction line and after a delay open the solenoid valve in the hot gas supply in order to build up the defrosting pressure in the evaporator. When the defrosting pressure reaches the set OFV-pressure, the OFV will open and the defrosting pressure will increase to the working pressure $\Delta P_{set} + \Delta P_{over}$.

After defrosting, it is normal practice to open the ICLX in the return line to equalize the pressure to the suction side before opening to the pump side.

Figure 1: Pressure/temperature control

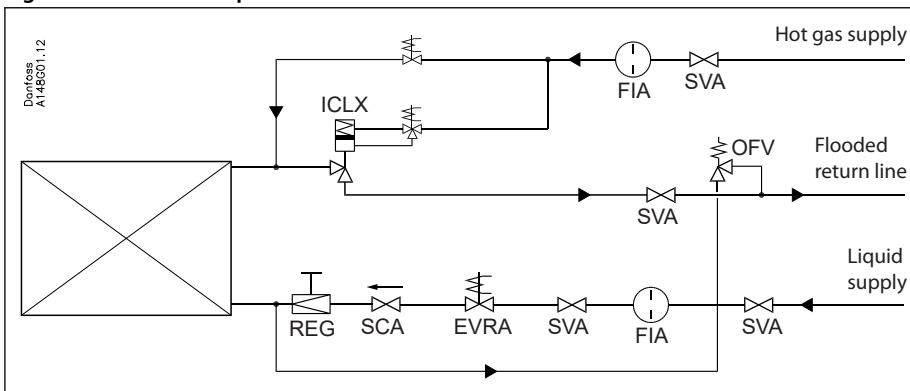

Media

Refrigerants

Applicable to HCFC, HFC, R717(Ammonia) and R744 (CO₂).

Flammable hydrocarbons are not recommended. For further information please contact your local Danfoss Sales Company.

New refrigerants

Danfoss products are continually evaluated for use with new refrigerants depending on market requirements.

When a refrigerant is approved for use by Danfoss, it is added to the relevant portfolio, and the R number of the refrigerant (e.g. R513A) will be added to the technical data of the code number. Therefore, products for specific refrigerants are best checked at store.danfoss.com/en/, or by contacting your local Danfoss representative.

Product specification

Design

Packing gland OFV

The “full temperature range” packing gland consists of a double O-ring sealing arrangement combined with permanent lubrication from a grease reservoir. This ensures perfect tightness throughout the whole range: -50/+150 °C (-58/+302 °F).

Flexible O-ring provides perfect sealing over the seat.

Packing gland OFV-SS

The stainless steel packing gland comprises a spring loaded seal packing gland which ensures a perfect tightness in the range: -60/+150 °C (-76/+302 °F).

The packing glands are equipped with a scraper ring to prevent penetration of dirt and ice into the packing gland.

Installation

The valve is designed to resist very high internal pressure, but as to the pipe system in general, hydraulic pressure caused by thermal expansions in entrapped refrigerants should be avoided. For further information please see OFV installation instruction.

Figure 2: Example of Marking Ring, Valve type OFV.

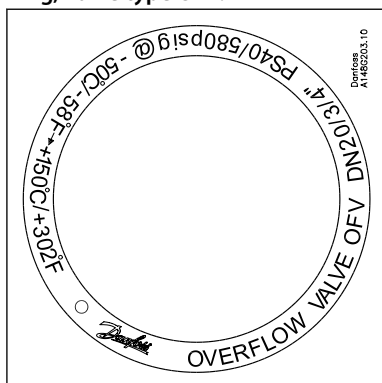

Pressure and temperature data

Table 1: Pressure and temperature range

Description	Values
Temperature range	OFV: -50/+150 °C (-58/+302 °F) OFV-SS: -60/+150 °C (-76/+302 °F)
Maximum operating pressure	OFV: 40 bar (580 psig) OFV-SS: 52 bar (754 psig)
Set pressure (ΔP)	2 - 8 bar (29 - 116 psi)

Understanding the OFV in practice

(when working in a defrosting application)

How the OFV works

The opening pressure of the OFV can be adjusted to a specific differential pressure ΔP_{set} by turning the spindle. ΔP_{set} indirectly determines the defrosting pressure.

As illustrated in [Figure 3: Pressure and temperature](#) the OFV will work at a pressure somewhat higher than ΔP_{set} , namely the ΔP_{total} which will be situated somewhere in the area marked with grey in [Figure 3: Pressure and temperature](#).

Figure 3: Pressure and temperature

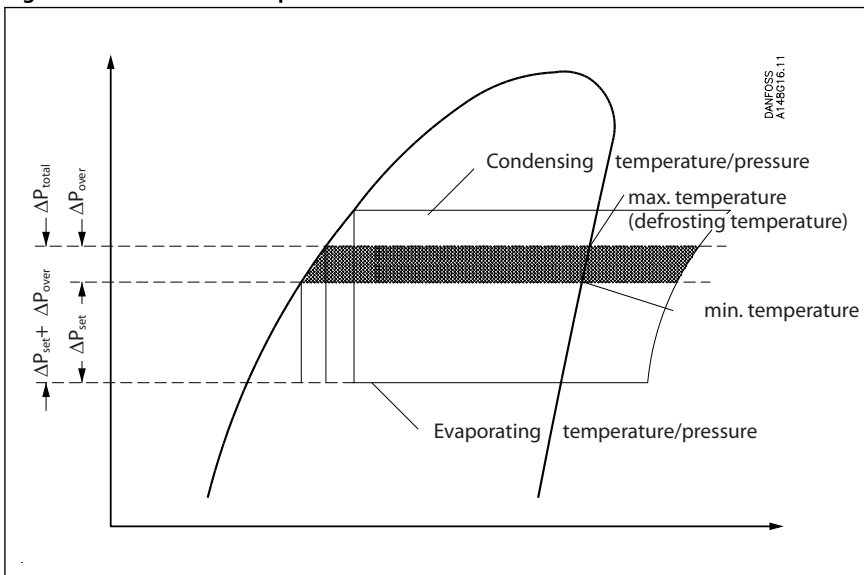

As ΔP_{over} is plant specific, it follows that the total working pressure ($\Delta P_{\text{total}} = \Delta P_{\text{set}} + \Delta P_{\text{over}}$) is plant specific too. By adjusting the opening differential pressure ΔP_{set} it is possible to adjust the working pressure $\Delta P_{\text{set}} + \Delta P_{\text{over}}$ until you get the required defrosting pressure.

$$\text{Defrosting pressure} \approx \text{Evaporating pressure} + \Delta P_{\text{set}} + \Delta P_{\text{over}}$$

! IMPORTANT:

The OFV valve is back pressure dependent.

Adjusting set pressure

The set pressure is the pressure at which the valve starts to open.

The set pressure is adjustable in the range 2 - 8 bar differential pressure. When the valve is delivered, a distance piece is supplied separately with the valve. The distance piece can be mounted under the spring, thus increasing the initial tension of the spring. Therefore the valve covers the complete range 2 - 8 bar differential pressure, as follows:

2 bar - 6.5 bar differential pressure without distance piece. 3.5 bar - 8 bar differential pressure with distance piece.

Figure 4: Adjusting set pressure

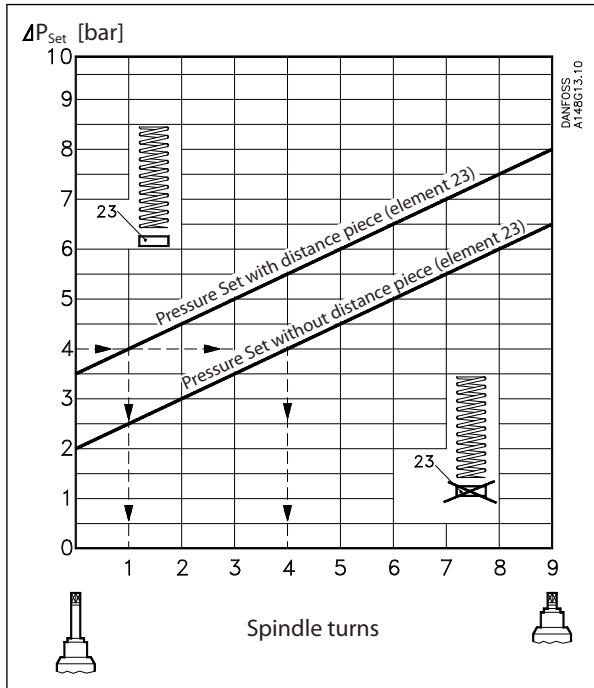

Illustrated figure shows set pressure as a function of the spindle turns

NOTE:

See material specification and installation and maintenance instruction for OFV.

Computation and selection

Figure 5: k_v values for OFV 20 - 25

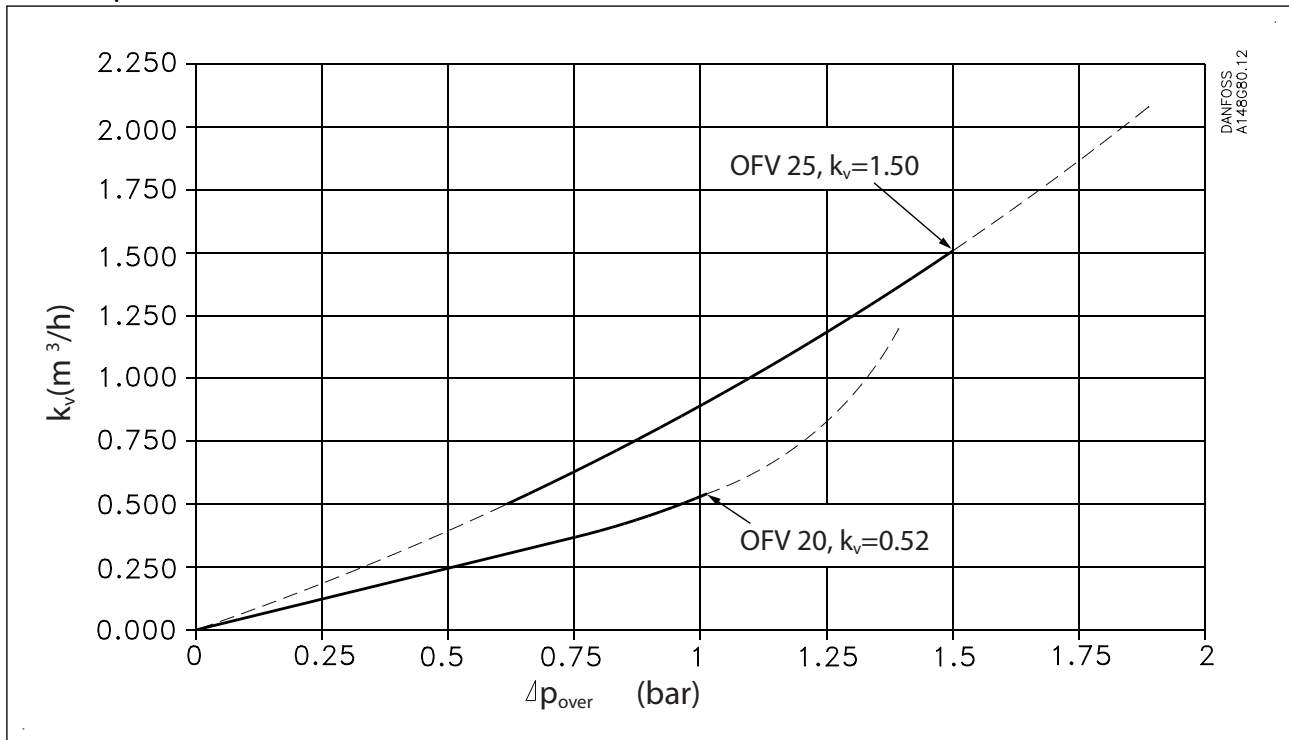

The capacity of the OFV valves can be calculated by the following formulas:

Liquids without phase change

$$G = k_v \sqrt{\rho \times \Delta P_{total} \times 1000}$$

Liquids with phase change (e.g. pressure control during defrost)

$$G = k_v \times 0.78 \sqrt{\rho \times \Delta P_{\text{total}} \times 1000}$$

G: mass flow (kg/h)

k_v : flow rate (m³/h) (the kv value is dependent on ΔP_{over} , see Figure 5: k_v values for OFV 20 - 25).

ρ : density, liquid (kg/m³)

ΔP_{bar} = differential pressure (bar)

$$\Delta P_{\text{bar}} = \Delta P_{\text{set}} + \Delta P_{\text{over}}$$

Defrosting pressure \approx Evaporating pressure + ΔP_{set} + ΔP_{over}

Capacity calculation for defrost pressure regulating

Table 2: Max. mass flow (G_{OFV}) for OFV 20 and OFV 25 with R717

Evaporating temperature	-10°C	-20°C	-30°C	-40°C	-50°C
Defrosting temperature	10°C				

Table 3: OFV 20

Mass flow $G_{\text{OFV 20}}$ (kg/h) ($\Delta P_{\text{over}} = 1 \text{ bar}$, $k_v = 0.52 \text{ m}^3/\text{h}$)	577	661	714	747	768
--	-----	-----	-----	-----	-----

Table 4: OFV 25

Mass flow $G_{\text{OFV 25}}$ (kg/h) ($\Delta P_{\text{over}} = 1.5 \text{ bar}$, $k_v = 1.5 \text{ m}^3/\text{h}$)	1666	1906	2059	2156	2216
---	------	------	------	------	------

NOTE:

The calculation is based on formula for "liquids with phase change" in the paragraph "Computation and selection".

Table 5: Calculating of refrigerant mass flow G_0

Evaporating temperature	-10°C	-20°C	-30°C	-40°C	-50°C
Mass flow G_0 (kg/h)	$2.780 \times Q_0$	$2.712 \times Q_0$	$2.651 \times Q_0$	$2.595 \times Q_0$	$2.544 \times Q_0$

Q_0 : Capacity of the evaporator (kW)

NOTE:

The calculation is based on pump circulating system (Liquid temperature = Evaporating temperature)

Guide line: Defrost capacity $G_{\text{OFV}} \sim (2 - 3) \times G_0$

Example:

An evaporator in a refrigerant plant has a capacity of $Q_0 = 150 \text{ kW}$ and a evaporating temperature of $-40 \text{ }^\circ\text{C}$. The defrosting temperature has to be controlled with an OFV valve.

Table 2: $G_0 = 2.595 \times Q_0 = 389 \text{ kg/h}$

The defrosting capacity in this example is $2.5 \times G_0$.

$G_{\text{OFV}} \geq 2.5 \times 389 = 972 \text{ kg/h}$.

OFV 25 is selected ($G_{\text{OFV 25 max.}} = 2156 \text{ kg/h}$ (Table 2: Max. mass flow (G_{OFV}) for OFV 20 and OFV 25 with R717)).

Material specification

Figure 6: OFV

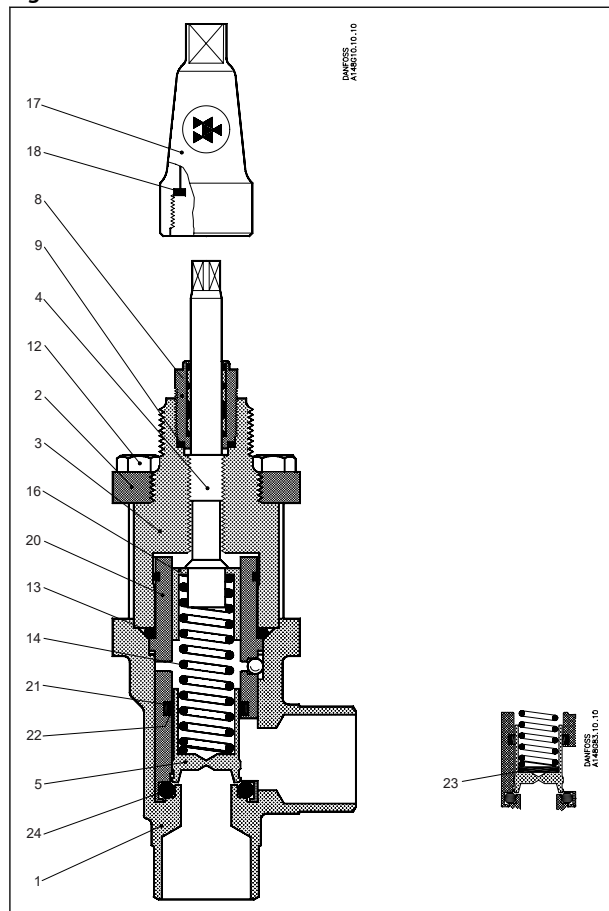

Table 6: Material and part list

No.	Part	Material	EN	ISO	ASTM
1	Housing	Steel	P285 QH EN10222-4		LFA350
2	Bonnet, Flange	Steel	P275 NL1 EN10028-3		
3	Bonnet, Insert	Steel			
4	Spindle	Stainless steel	X10 CrNi S18-9 17440	Type 17 683/13	AISI 303
5	Cone	Steel			
8	Packing gland	Steel			
9	Packing washer	Aluminium			
12	Bolts	Stainless steel	A2-70	A2-70	Type 308
13	O-ring	Cloroprene (Neoprene)			
14	Spring	Steel			
16	Spring washer	Steel			
17	Cap	Aluminium			
18	Gasket for cap	Nylon			
20	Guide piece	Steel			
21	O-ring	Cloroprene (Neoprene)			
22	Sealing ring	PTFE (Teflon)			
23	Distance piece	Steel			
24	O-ring	Cloroprene (Neoprene)			

Figure 7: OFV-SS 20 - 25 (3/4 - 1")

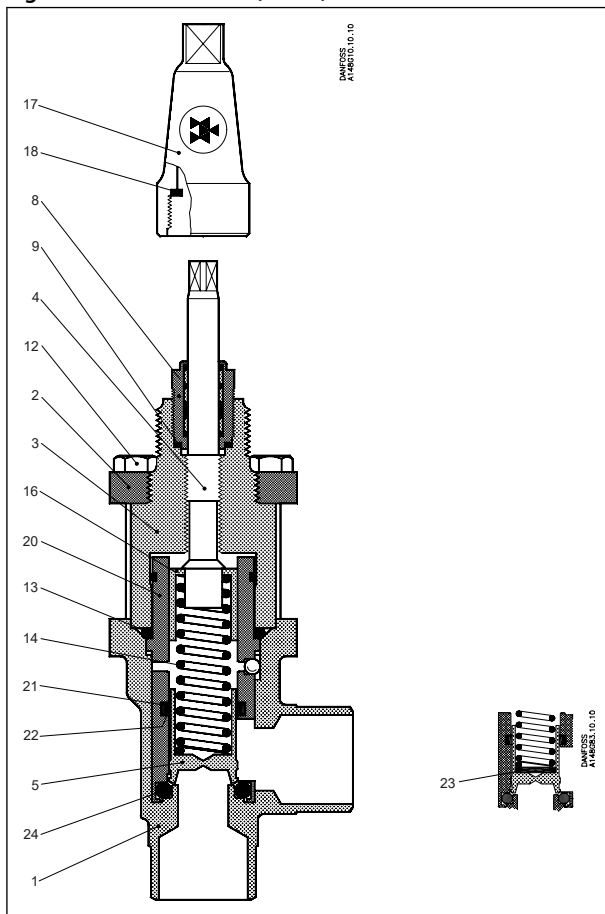

Table 7: Material and part list

No.	Part	Material	EN	ISO	ASTM
1	Housing	Stainless steel	X5CrNi18-10 EN10088		AISI 304
2	Bonnet, Flange	Stainless steel	X5CrNi18-10 EN10088		AISI 304
3	Bonnet, Insert	Stainless steel			
4	Spindle	Stainless steel	X8CrNi18-9 DIN 17440	Type 17 683/13	AISI 303
5	Cone	Steel	9SMn28	Type 2	1213
8	Packing gland	Stainless steel			
9	Packing washer	Non asbestos			
12	Bolts	Stainless steel	A2-70	A2-70	Type 308
13	O-ring	Cloroprene (Neoprene)			
14	Spring	Steel			
16	Spring washer	Steel	Steel		
17	Spindle seal cap	Aluminium			
18	Seal cap gasket	Nylon			
20	Guide piece	Steel			
21	O-ring	Cloroprene (Neoprene)			
22	Sealing ring	PTFE (Teflon)			
23	Distance piece	Steel			
24	O-ring	Cloroprene (Neoprene)			

Connections

Available with the following connections:

- Welding DIN (EN 10220)
- Welding ANSI (B 36.19M)

Figure 8: DIN

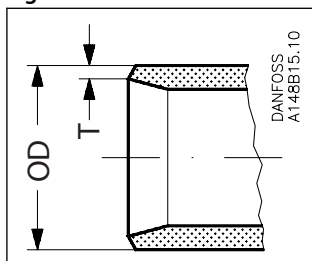

Table 8: Butt-weld DIN (EN 10220)

Size mm	Size in.	OD mm	T mm	OD in.	T in.	k_v -angle m ³ /h	C_v -angle USgal/min
20	¾	26.9	2.3	1.06	0.09	0 - 0.52	0 - 0.60
25	1	33.7	2.6	1.33	0.10	0 - 1.50	0 - 1.74

Figure 9: ANSI

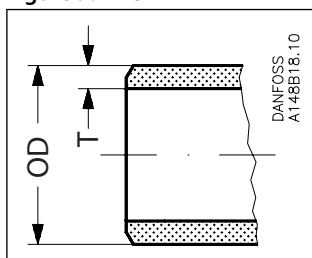

Table 9: Butt-weld ANSI (B 36.10M)

Size mm	Size in.	OD mm	T mm	OD in.	T in.	k_v -angle m ³ /h	C_v -angle USgal/min
20	¾	26.9	4.0	1.06	0.16	0 - 0.52	0 - 0.60
25	1	33.7	4.6	1.33	0.18	0 - 1.50	0 - 1.74

Table 10: Butt-weld ANSI (B 36.19M, SCHEDULE 40)

Size mm	Size in.	OD mm	T mm	OD in.	T in.	k_v -angle m ³ /h	C_v -angle USgal/min
20	¾	26.9	2.9	1.06	0.11	0 - 0.52	0 - 0.60
25	1	33.7	3.5	1.33	0.14	0 - 1.50	0 - 1.74

Dimensions and weights

Figure 10: OFV 20 - 25

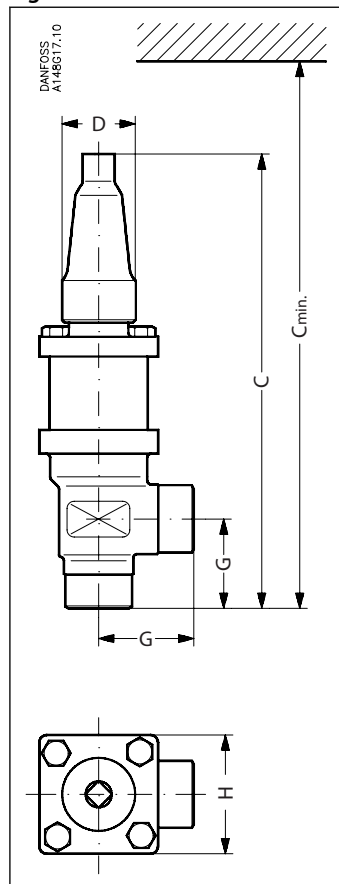

Table 11: OFV 20 - 25

Valve size		G	C	C _{min}	ØD	H	Weight
OFV 20 (¾)	mm	45	230	290	38	60	2.0 kg
	in.	1.77	9.1	11.4	1.5	2.4	4.4 lb
OFV 25 (1 in.)	mm	45	230	290	38	60	2.0 kg
	in.	1.77	9.1	11.4	1.5	2.4	4.4 lb

NOTE:

Specified weights are approximate values only.

Ordering

How to order

The table below is used to identify the valve required.

Please note that the type codes only serve to identify the valves, some of which may not form part of the standard product range.

For further information please contact your local Danfoss Sales Company.

Table 12: Type codes

Valve type	OFV OFV-SS	Over Flow Valve in carbon steel Over Flow Valve in stainless steel
Nominal size in mm	20 25	DN 20 DN 25
Connections	D A	Butt-weld connection: DIN EN 10220 Butt-weld connection: ANSI B 36.19M
Valve housing	1	Angle flow
Materials	3	Housing: P285 QH, Bonnet: P275 NL1
Other equipment	3	Cap, short spindle with Chloroprene (Neoprene) O-ring

Table 13: Example for type codes

OFV	25	D	1	3	3
-----	----	---	---	---	---

ⓘ IMPORTANT:

Where products need to be certified according to specific certification societies or where higher pressures are required, the relevant information should be included at the time of order.

Table 14: Opening differential pressure 2 - 8 bar (29 - 116 psi):

Size		Type	Code No.
mm	in		
20	¾	OFV 20 A 133	2412+185
20	¾	OFV 20 D 133	2412+183
20	¾	OFV-SS 20 D ANG OVER FLOW VALVE 52 bar	148G3194
25	1	OFV 25 A 133	2412+186
25	1	OFV 25 D 133	2412+184
25	1	OFV-SS 25 A ANG OVER FLOW VALVE 52 bar	148G3843
25	1	OFV-SS 25 D ANG OVER FLOW VALVE 52 bar	148G3195

Certificates, declarations, and approvals

The list contains all certificates, declarations, and approvals for this product type. Individual code number may have some or all of these approvals, and certain local approvals may not appear on the list.

Some approvals may change over time. You can check the most current status at danfoss.com or contact your local Danfoss representative if you have any questions.

Table 15: Pressure Equipment Directive (PED)

	OFV valves are approved and CE-marked in accordance with the Pressure Equipment Directive - 97/23/EC.
---	---

For further details / restrictions - see Installation Instruction

Table 16: OFV

	OFV		
Nominal bore	DN≤ 25 mm (1 in.)		
Classified for	Fluid group I		
Category	Article 3, paragraph 3		

File name	Document type	Document topic	Approval authority
RU Д-ДК.БЛ08.В.00191_18	EAC Declaration	Machinery & Equipment	EAC
033F0691.AE	Manufacturers Declaration	RoHS	Danfoss
033F0686.AH	Manufacturers Declaration	PED	Danfoss
033F0473.AD	Manufacturers Declaration	ATEX	Danfoss
19.10327.266	Marine - Safety Certificate	-	RMRS

Online support

Danfoss offers a wide range of support along with our products, including digital product information, software, mobile apps, and expert guidance. See the possibilities below.

The Danfoss Product Store



The Danfoss Product Store is your one-stop shop for everything product related—no matter where you are in the world or what area of the cooling industry you work in. Get quick access to essential information like product specs, code numbers, technical documentation, certifications, accessories, and more.

Start browsing at store.danfoss.com.

Find technical documentation



Find the technical documentation you need to get your project up and running. Get direct access to our official collection of data sheets, certificates and declarations, manuals and guides, 3D models and drawings, case stories, brochures, and much more.

Start searching now at www.danfoss.com/en/service-and-support/documentation.

Danfoss Learning



Danfoss Learning is a free online learning platform. It features courses and materials specifically designed to help engineers, installers, service technicians, and wholesalers better understand the products, applications, industry topics, and trends that will help you do your job better.

Create your Danfoss Learning account for free at www.danfoss.com/en/service-and-support/learning.

Get local information and support



Local Danfoss websites are the main sources for help and information about our company and products. Find product availability, get the latest regional news, or connect with a nearby expert—all in your own language.

Find your local Danfoss website here: www.danfoss.com/en/choose-region.

Spare Parts



Get access to the Danfoss spare parts and service kit catalog right from your smartphone. The app contains a wide range of components for air conditioning and refrigeration applications, such as valves, strainers, pressure switches, and sensors.

Download the Spare Parts app for free at www.danfoss.com/en/service-and-support/downloads.

Coolselector®2 - find the best components for you HVAC/R system



Coolselector®2 makes it easy for engineers, consultants, and designers to find and order the best components for refrigeration and air conditioning systems. Run calculations based on your operating conditions and then choose the best setup for your system design.

Download Coolselector®2 for free at coolselector.danfoss.com.

Danfoss A/S

Climate Solutions • danfoss.com • +45 7488 2222

Any information, including, but not limited to information on selection of product, its application or use, product design, weight, dimensions, capacity or any other technical data in product manuals, catalogues descriptions, advertisements, etc. and whether made available in writing, orally, electronically, online or via download, shall be considered informative, and is only binding if and to the extent, explicit reference is made in a quotation or order confirmation. Danfoss cannot accept any responsibility for possible errors in catalogues, brochures, videos and other material. Danfoss reserves the right to alter its products without notice. This also applies to products ordered but not delivered provided that such alterations can be made without changes to form, fit or function of the product.

All trademarks in this material are property of Danfoss A/S or Danfoss group companies. Danfoss and the Danfoss logo are trademarks of Danfoss A/S. All rights reserved.