

Technical brochure

Regulating valves

REG 6-65, REG-SS 15-40

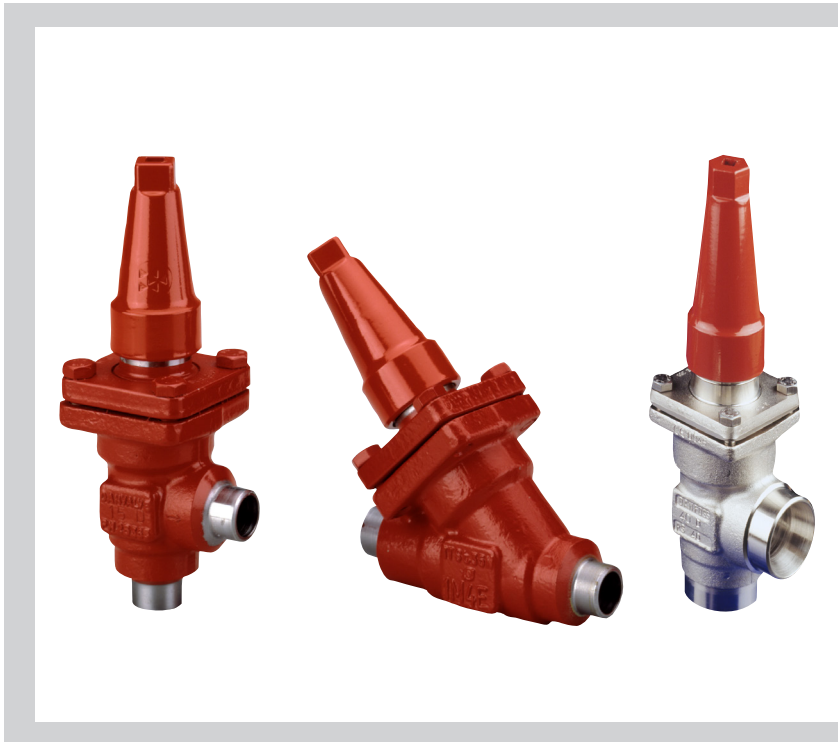

REG are angle-way and straight-way regulating valves, which act as normal stop valves in closed position.

The valves are designed to meet the strict quality requirements on refrigerating installations specified by the international classification societies and are carefully designed to present favourable flow conditions and accurate linear characteristics.

REG are equipped with vented cap and have internal backseating enabling the spindle seal to be replaced with the valve still under pressure.

Features

- Applicable to all common non flammable refrigerants including R 717 and non corrosive gases/liquids dependent to sealing material compatibility
- Designed to ensure perfect regulation
- Internal backseating enables replacement of the spindle seal whilst the valve is active, i.e. under pressure
- Easy to disassemble for inspection and possible repair
- Max. operating pressure:
REG: 40 bar g (580 psi g)
REG-SS: 52 bar g (754 psi g)
(valves for higher operating pressure available on request)
- Full temperature range packing gland
-50/+150°C (-58/+302°F)
- Low temperature range packing gland for REG-SS
-60/+150°C (-76/+302°F)
- Act as a normal stop valve in closed position
- Housing and bonnet material is low temperature steel (REG-SS in stainless steel) according to requirements of the Pressure Equipment Directive and other international classification authorities
- Exact capacity and setting of the valve can be calculated for all refrigerants by means of "DIRcalc™" (Danfoss Industrial Refrigeration calculation programme)
- Classification: To get an updated list of certification on the products please contact your local Danfoss Sales Company.

Content	Page
Features.....	1
Design	3
Technical data	3
Computation and selection	4
Material specification	14
Connections.....	16
Dimensions and weights.....	17
Ordering	19

Design
Housing

Made of special, cold resistant steel (stainless steel for REG-SS) approved for low temperature operation.

Connections

Available with the following connections:

- Butt-weld DIN (EN 10220)
– DN 6 - 65 (¼ - 2½ in.)
- Butt-weld ANSI (B 36.10 Schedule 80)
– DN 6 - 40 (¼ - 1½ in.)
- Butt-weld ANSI (B 36.10 Schedule 40)
– DN 50 - 65 (2 - 2½ in.)
- Socket weld (ANSI B 16.11)
– DN 15 - 40 (½ - 1½ in.)
- Soldering connections (ANSI B 16.22)
– DN 10 - 22 (¾ - 7/8 in.)
- FPT inside pipe thread, NPT (ANSI/ASME B 1.20.1)
– DN 15 - 32 (½ - 1¼ in.)

Valve cone

The valve cone is designed to ensure perfect regulation. A wide programme of valves and

various precision cones provide an extensive regulating area, and irrespective of the refrigerant used, it is easy to obtain the correct capacity (see fig. 1). A cone seal ring provides perfect sealing at a minimum closing momentum.

The valve cone can be turned on the spindle, thus there will be no friction between the cone and the seat when the valve is opened and closed.

Spindle

Made of polished stainless steel, which is ideal for O-ring sealing.

Packing gland - REG

The “full temperature range” packing gland ensures perfect tightness in the whole range: –50/+150°C (–58/+302°F). The packing glands are equipped with a scraper ring to prevent penetration of dirt and ice into the packing gland.

Packing gland - REG-SS (Stainless steel version):

The stainless steel packing gland comprises a spring loaded seal packing gland which ensures a perfect tightness in the range –60/+150°C (–76/+302°F). The packing glands are equipped with a scraper ring to prevent penetration of dirt and ice into the packing gland.

Installation

Install the valve with the spindle up or in horizontal position. The flow must be directed towards the cone.

The valve is designed to withstand high internal pressure. However, the piping system in general should be designed to avoid liquid traps and reduce the risk of hydraulic pressure caused by thermal expansion.

For further information refer to installation instruction for REG.

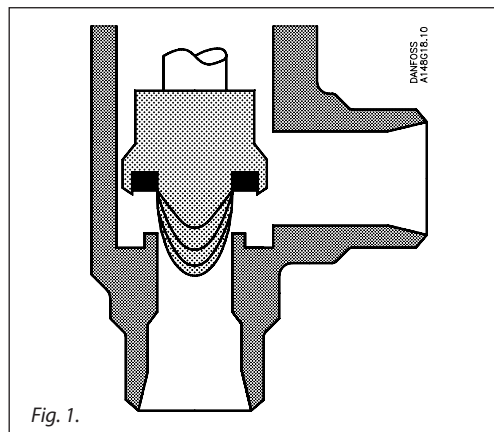

Fig. 1.

Pressure Equipment Directive (PED)

REG valves are approved according to the European standard specified in the Pressure Equipment Directive and are CE marked.

For further details / restrictions - see Installation Instruction.

REG valves	
Nominal bore	DN32 - 65 (1¼ - 2½ in.)
Classified for	Fluid group I
Category	II

Technical data

- *Refrigerants*
Applicable to all common non flammable refrigerants including R 717 and non corrosive gases/liquids dependent on sealing material compability.
For further information please see installation instruction for REG.
Flammable hydrocarbons are not recommended. For further information please contact your local Danfoss Sales Company.
- *Temperature range*
REG: –50/+150°C (–58/+302°F).
REG-SS: –60/+150°C (–76/+302°F)
- *Pressure range*
Max. operating pressure:
REG: 40 bar g (580 psig).
REG-SS: 52 bar g (754 psi g)
Valves for higher working pressure are available on request.
- *Flow coefficients*
Flow coefficients for fully opened valves from $k_v = 0.17$ to $81.4 \text{ m}^3/\text{h}$ ($C_v = 0.12$ to $57.3 \text{ USgal}/\text{min}$)

Computation and selection
Introduction

In refrigeration plants, regulating valves are primarily used in liquid lines in order to regulate the flow of refrigerant. The valves can, however, also be used as expansion valves. From a calculation point of view the two fields of application are very different.

Normal flow is the term used to describe the general case where the flow through the valve is proportional to the square root of the pressure drop across it and inversely proportional to the density of the refrigerant (Bernoulli's equation).

This relationship between mass flow, pressure drop and density satisfies the majority of all valve applications with refrigerants and brines.

Normal flow is characterised by turbulent flow through the valve without any phase change. The following capacity curves are based on the above mentioned assumption.

Application of the regulating valves outside the normal flow area will reduce the capacity of the valve considerably. In such cases it is recommended to use "DIRcalc™" (Danfoss Industrial Refrigeration calculation programme).

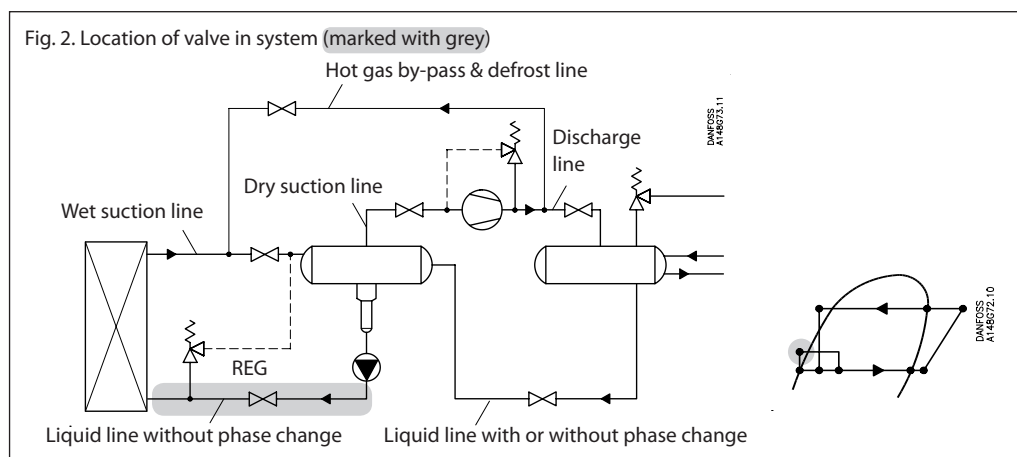
Sizing regulating valve for liquid flow

Liquid refrigerants: Use the liquid tables, fig. 8 - 17. For other refrigerants and brines, "Normal flow" (Turbulent flow); see below and use the flow coefficient tables (fig. 3 - 7).

SI-units

Mass flow:

$$k_v = \frac{G}{\sqrt{\rho \times 1000 \times \Delta p}} = G \times C_A \text{ [m}^3/\text{h]}$$

Volume flow:

$$k_v = \frac{\dot{V}}{\sqrt{\frac{1000 \times \Delta p}{\rho}}} \text{ [m}^3/\text{h]}$$

American units

Mass flow:

$$C_v = \frac{0.95 \times G}{\sqrt{\rho \times \Delta p}} = 31.6 \times G \times C_A \text{ [USgal/min.]}$$

Volume flow:

$$C_v = \frac{0.127 \times \dot{V}}{\sqrt{\frac{\Delta p}{\rho}}} \text{ [USgal/min.]}$$

k_v	[m ³ /h]	Quantity [m ³ /h] of water flowing through a valve at a pressure loss of 1 bar (according to VDE/VDI Norm 2173).	C_v	[US gal/min]	Quantity [US gal/min] of water flowing through a valve at a pressure loss of 1 psi.
P_1	[bar]	Pressure before the valve (upstream).	P_1	[psi]	Pressure before the valve (upstream).
P_2	[bar]	Pressure after the valve (downstream).	P_2	[psi]	Pressure after the valve (downstream).
Δp	[bar]	Actual pressure loss across the valve ($P_1 - P_2$).	Δp	[psi]	Actual pressure loss across the valve ($P_1 - P_2$).
G	[kg/h]	Mass flow through the valve.	G	[lb/min]	Mass flow through the valve.
\dot{V}	[m ³ /h]	Volume flow through the valve.	\dot{V}	[US gal/min]	Volume flow through the valve.
ρ	[kg/m ³]	Density of the refrigerant before the valve.	ρ	[lb/ft ³]	Density of the refrigerant before the valve.
C_A		Calculation factor (fig. 18).	C_A		Calculation factor (fig. 18).

Computation and selection

Flow coefficient

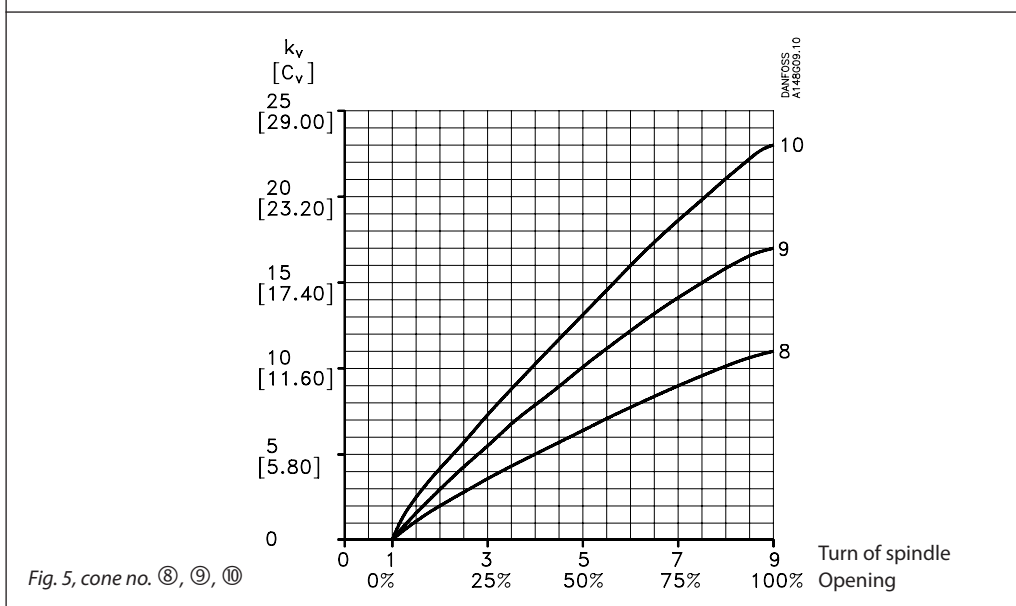
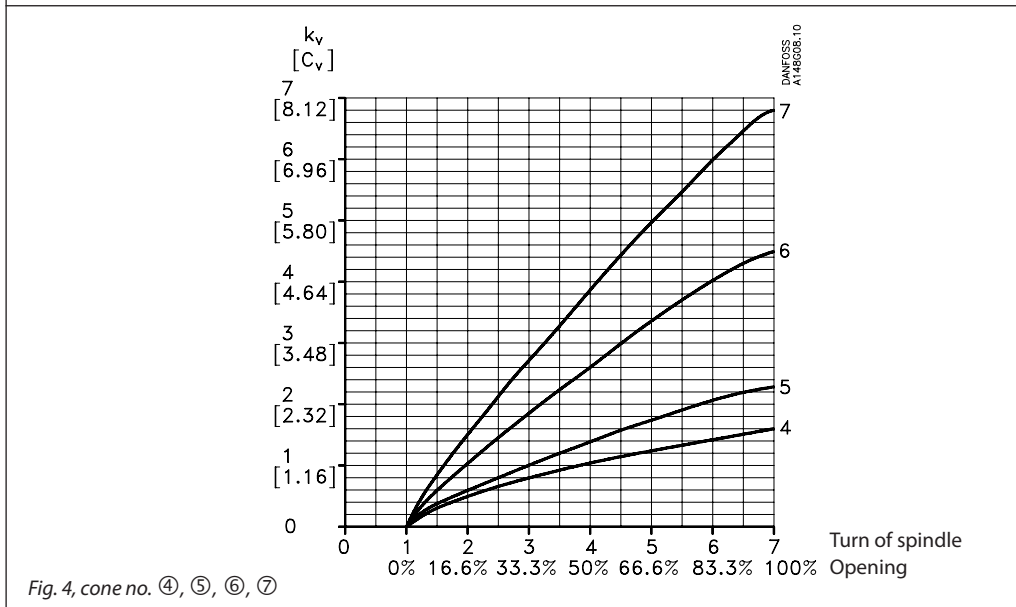
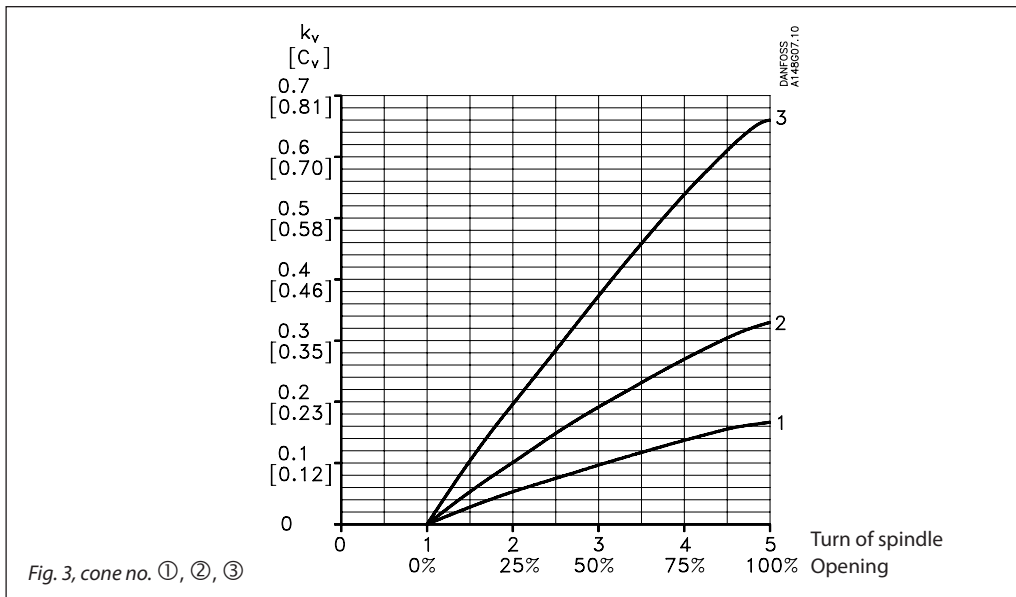

For choice of valve size and connection see "Connections".

Computation and selection

Flow coefficient

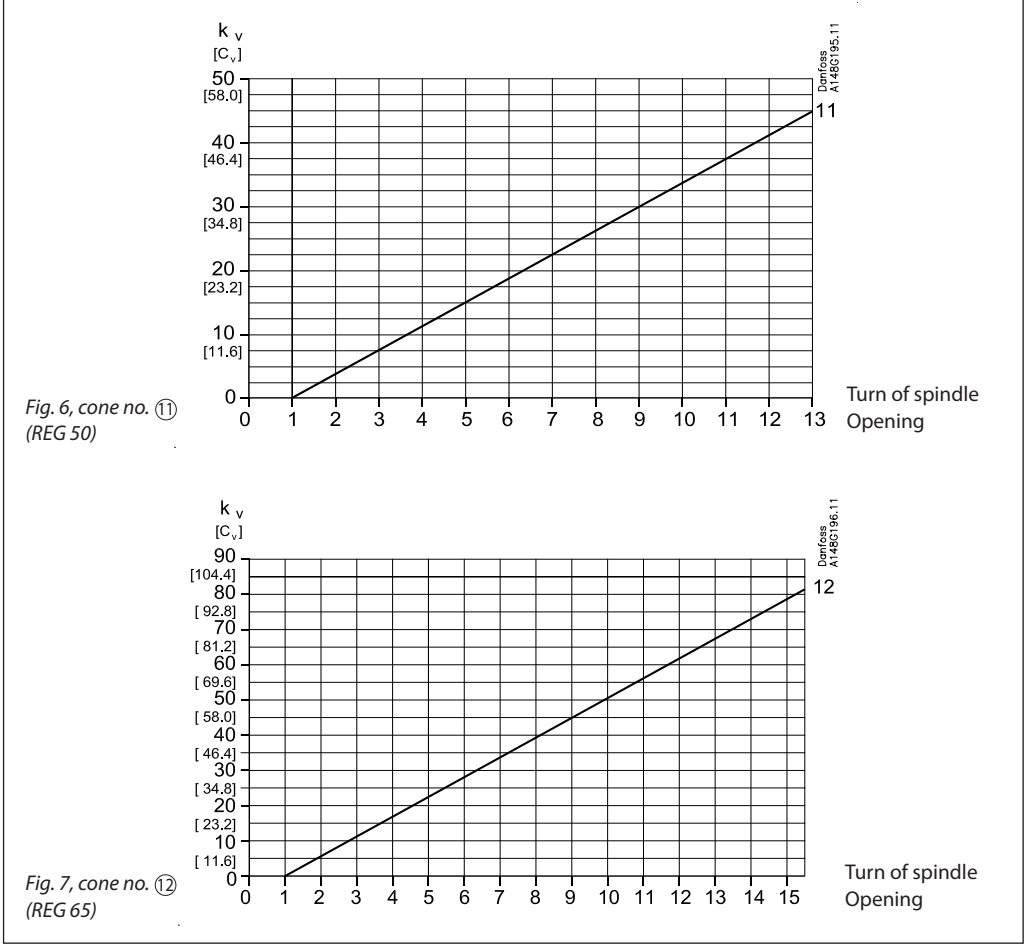

Liquid R 717, density: 670 kg/m³ [42 lb/ft³]

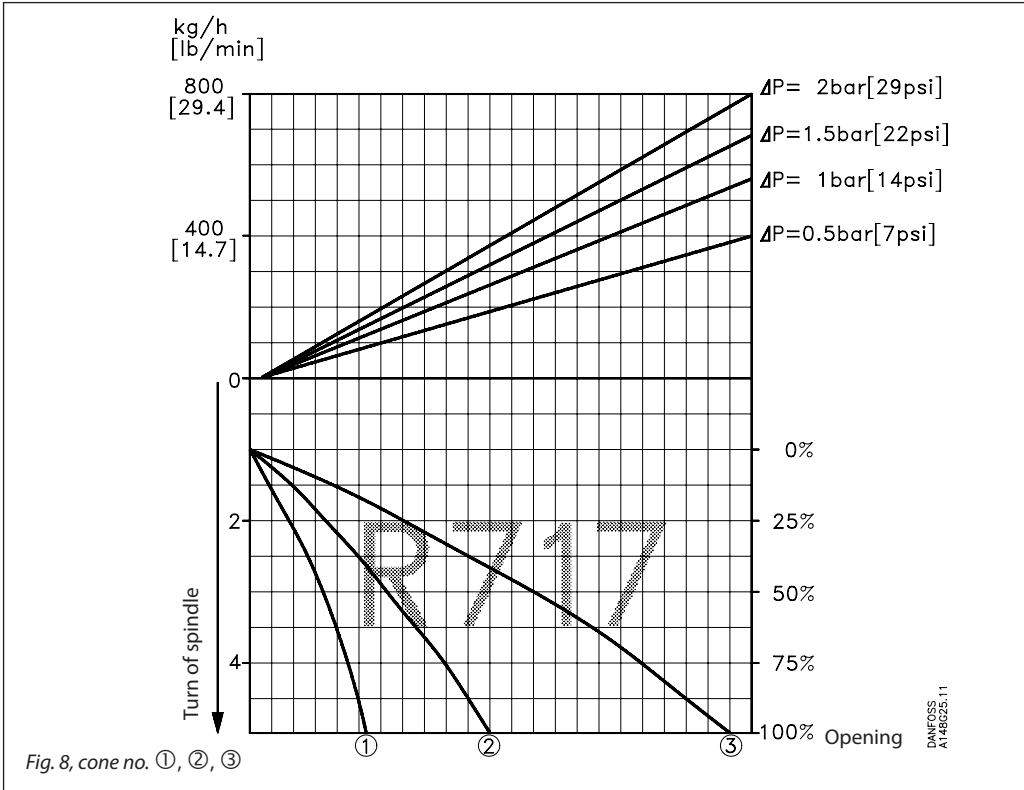

For choice of valve size and connection see "Connections".

Computation and selection

Liquid R 717, density: 670 kg/m³ [42 lb/ft³]

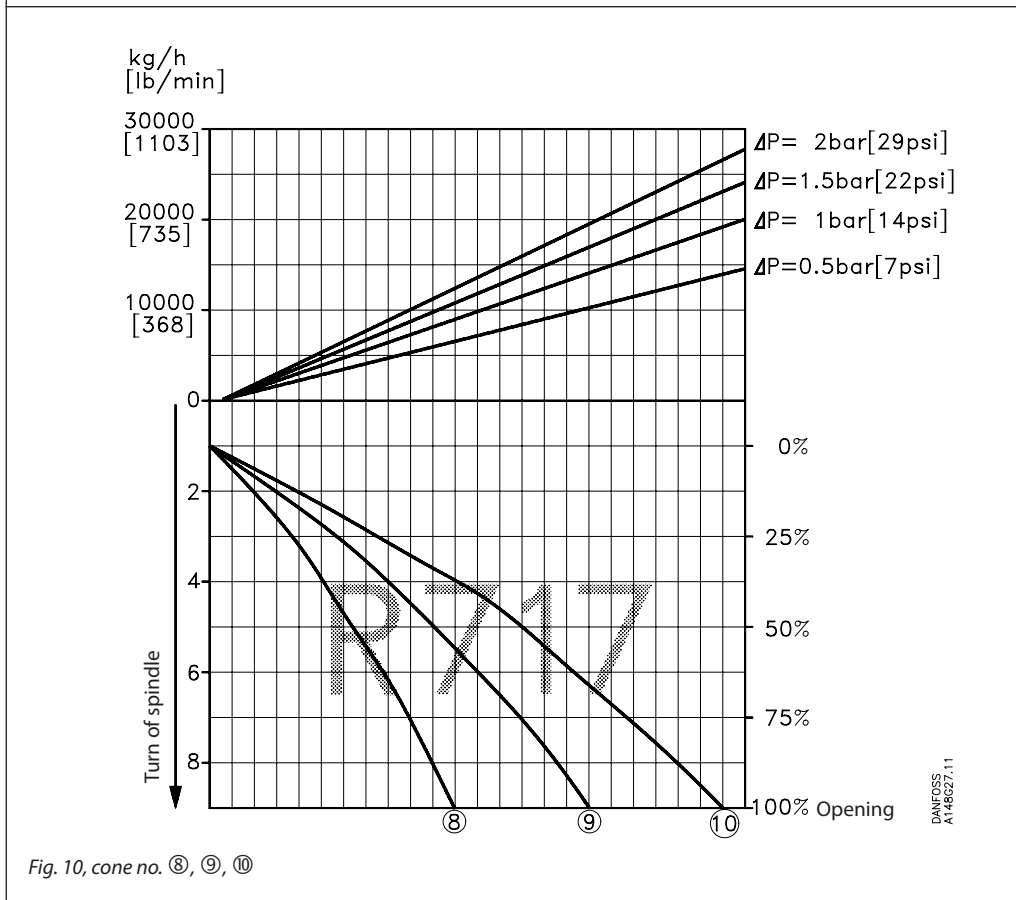
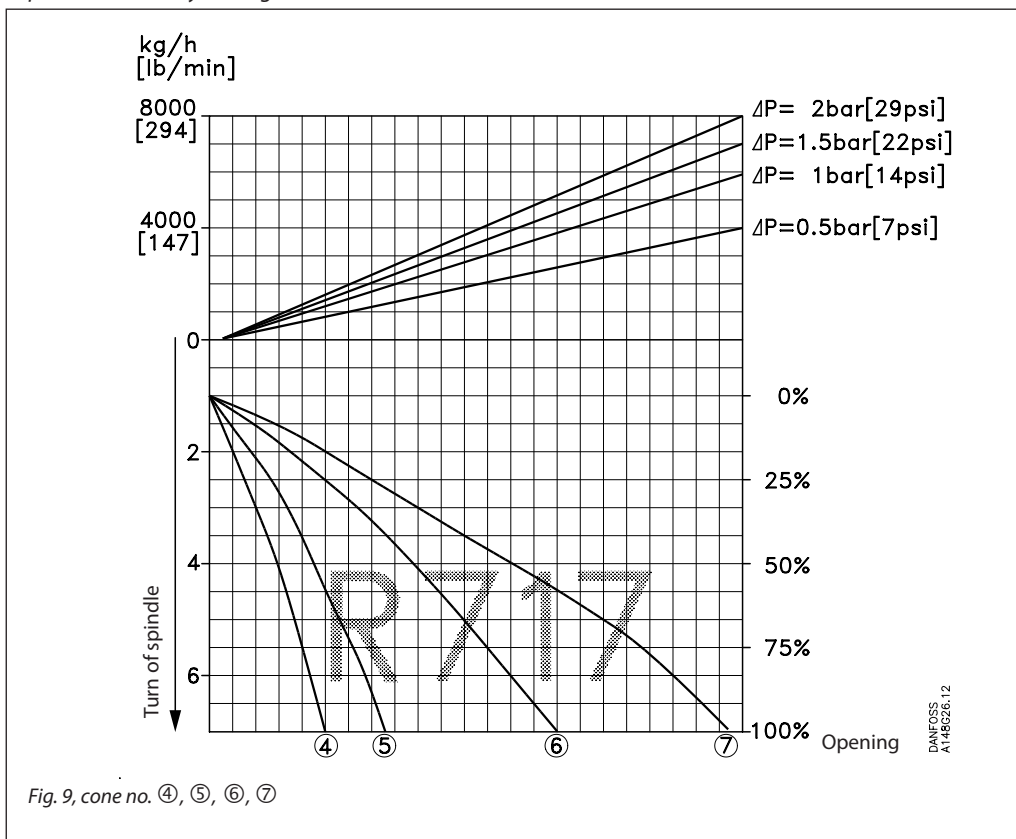

For choice of valve size and connection see "Connections".

Computation and selection

Liquid R 717, density: 670 kg/m³ [42 lb/ft³]

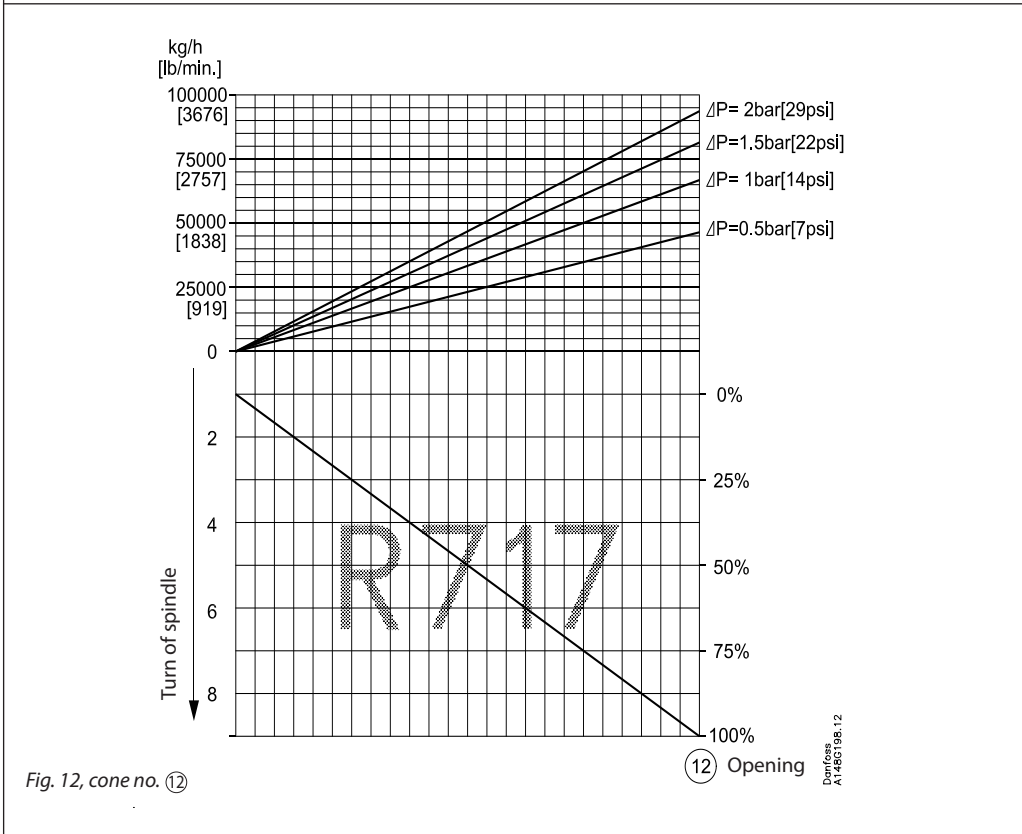
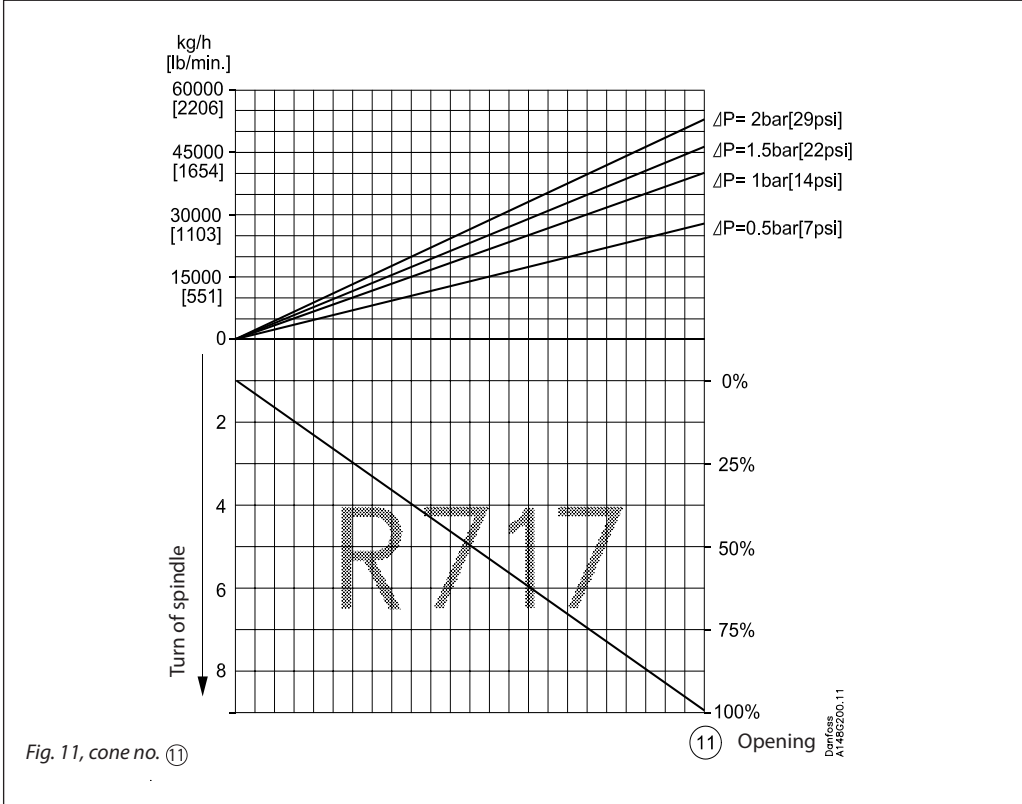

For choice of valve size and connection see "Connections".

Computation and selection

Liquid R 22, density: 1360 kg/m³ [85 lb/ft³]

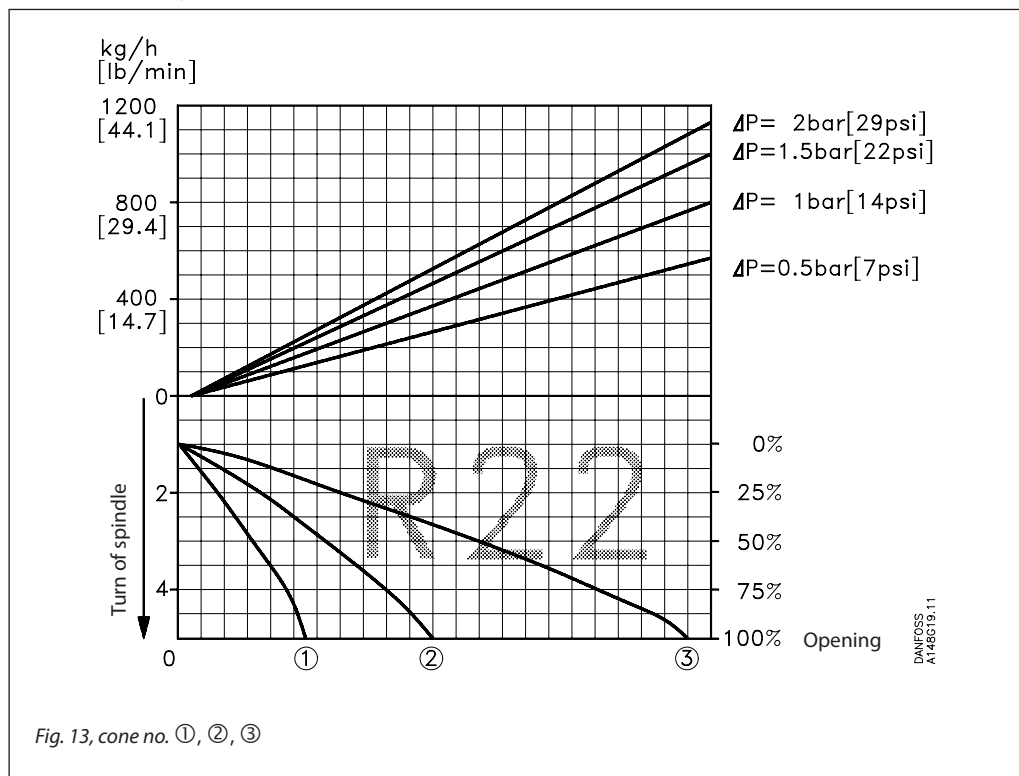

Fig. 13, cone no. ①, ②, ③

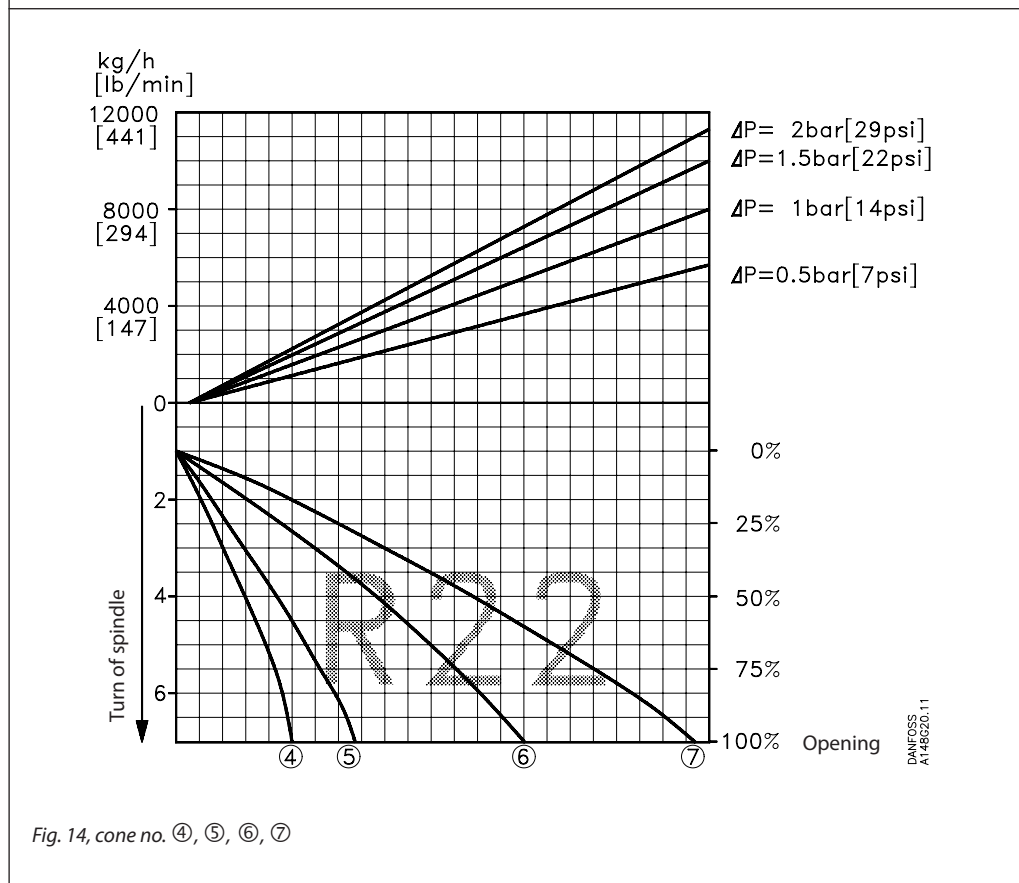

Fig. 14, cone no. ④, ⑤, ⑥, ⑦

For choice of valve size and connection see "Connections".

Computation and selection

Liquid R 22, density: 1360 kg/m³ [85 lb/ft³]

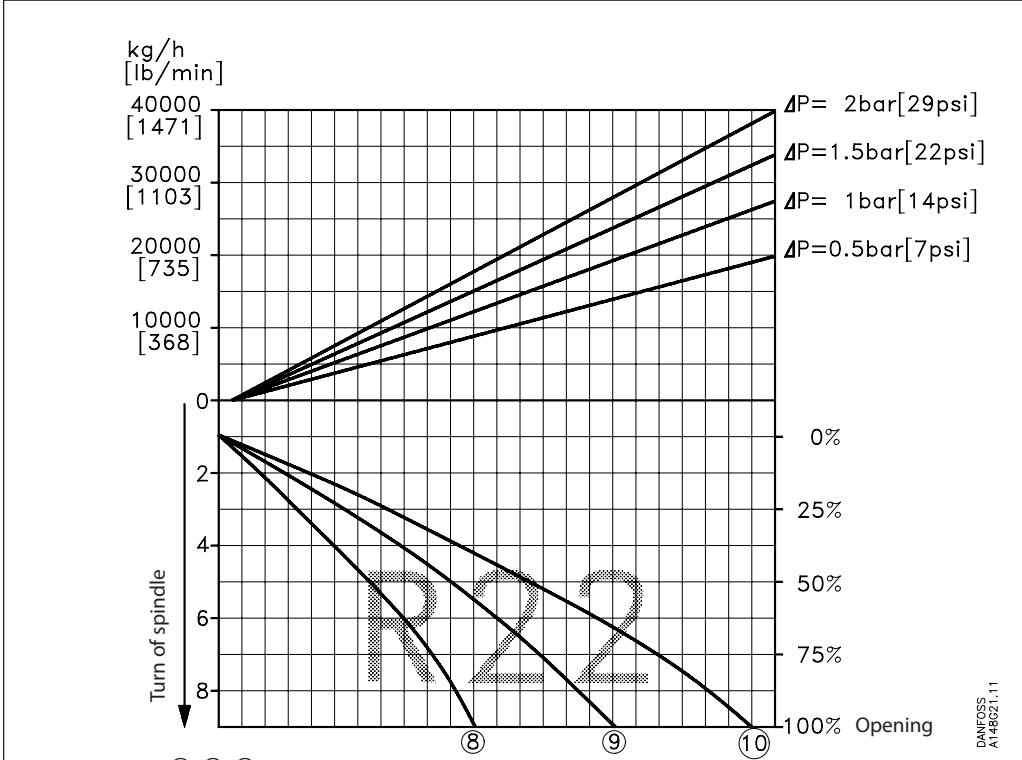

Fig. 15, cone no. ⑧, ⑨, ⑩

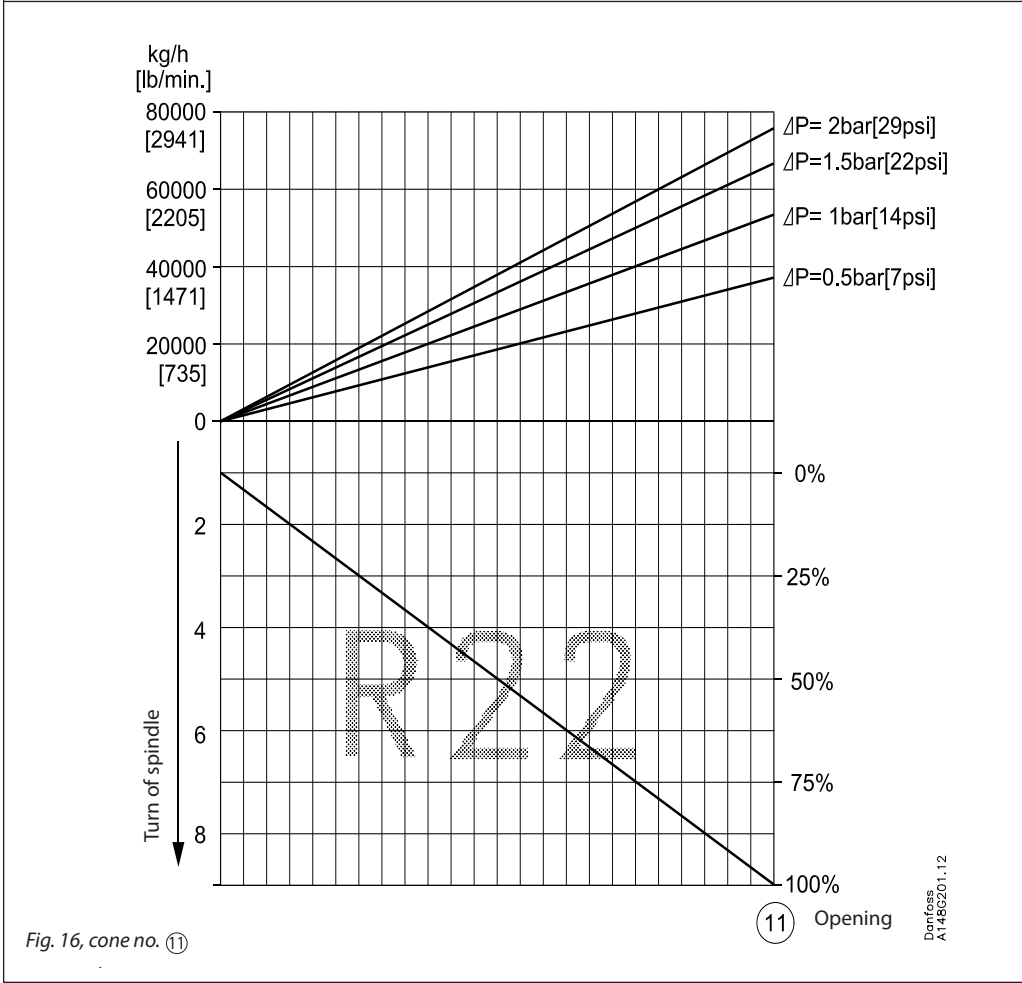
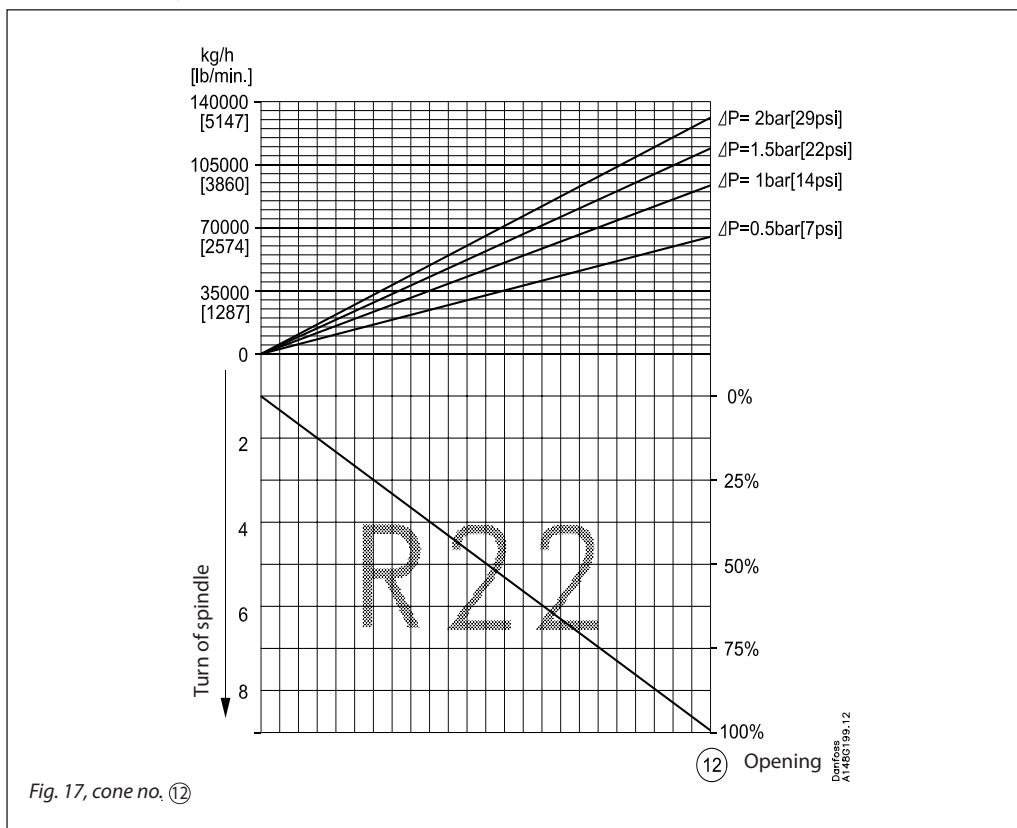

Fig. 16, cone no. ⑪

For choice of valve size and connection see "Connections".

Computation and selection

Liquid R 22, density: 1360 kg/m³ [85 lb/ft³]



Calculation factor C_A

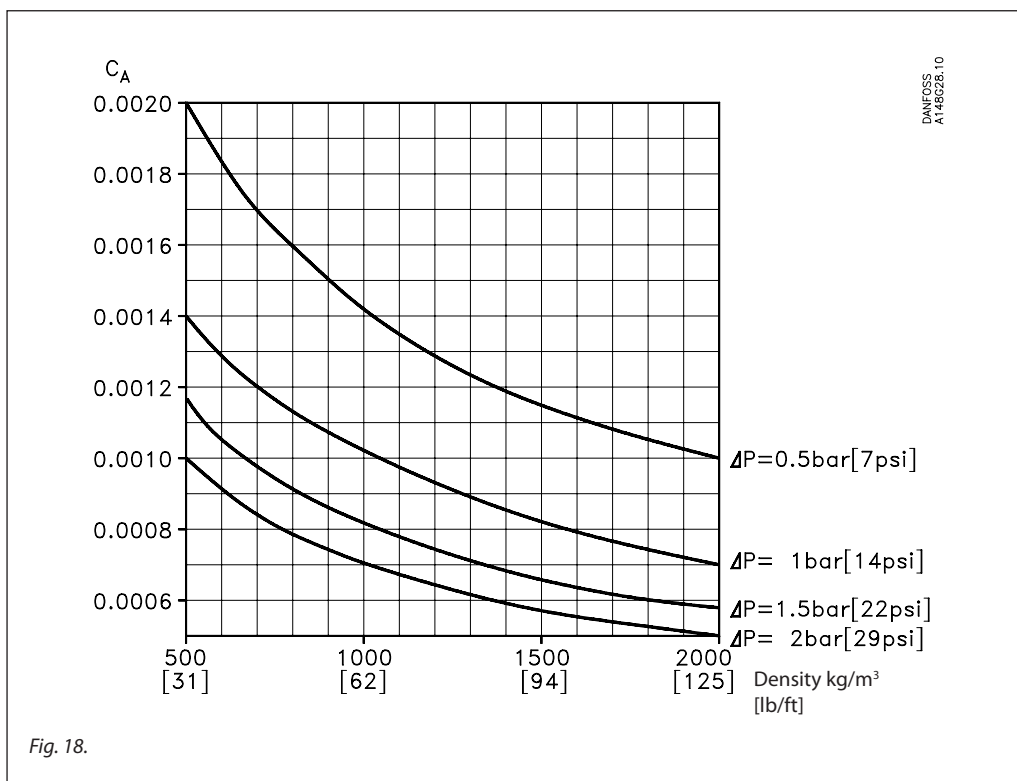

For choice of valve size and connection see "Connections".

Regulating valves, types REG 6 - 65 and REG-SS 15-40

Computation and selection
Example 1.

Refrigerant: R 717
 Refrigerant flow: 2500 [kg/h]
 Pressure drop: $\Delta p = 0.5$ [bar]

would be > 85%. In this case cone number 7 ~ 55% is recommended.

The above mentioned example is illustrated on the following flow rate diagram and shows that cone number 6 and 7 can be used. The main rule is that the cone with the minimum flow area gives the optimum regulation. However, owing to uncertainties cone number 6 opening degree

The example is only correct if the density of the refrigerant is approx. 670 (kg/m³), and there must be no build-up of flash gas in the valve.

Flow rate diagram

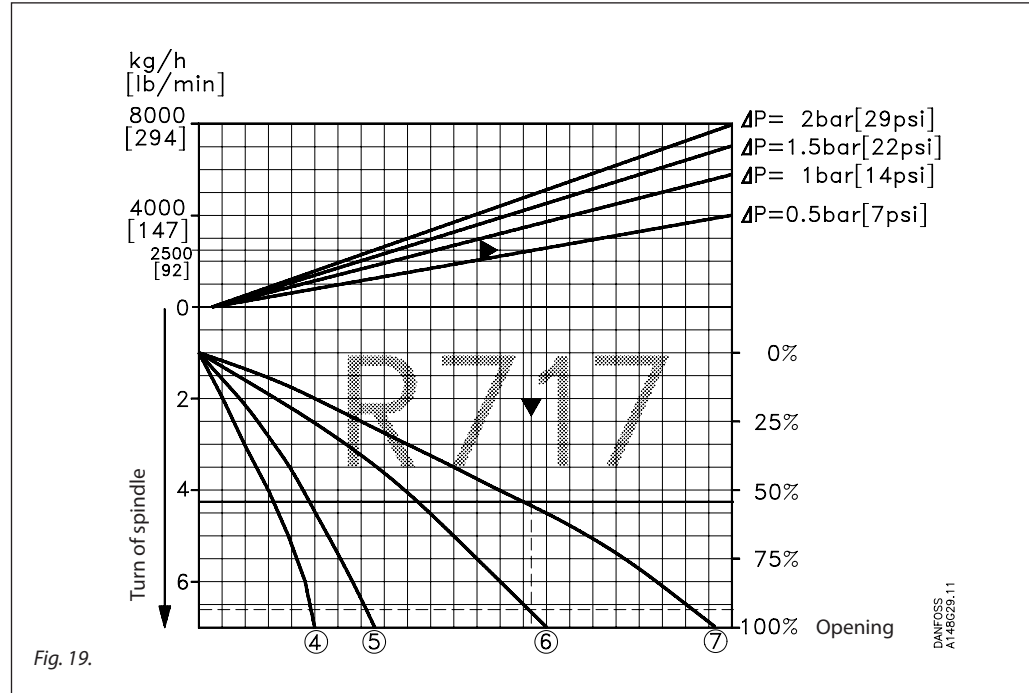

Fig. 19.

For choice of valve size and connection see "Connections".

Regulating valves, types REG 6 - 65 and REG-SS 15-40

Computation and selection

Example 2.

Brine, density ρ : 1150 [kg/m³]
 Brine flow G : 2,700 [kg/h]
 Pressure drop Δp : 0.5 [bar]

In this example it is not possible to use the selection diagrams (fig. 8 - 17) as the refrigerant in question is not included.

Either use the curves of the k_v -values instead (fig. 3 - 7) and calculate the required k_v by means of the formulas in the "Introduction" passage at the beginning of this chapter. Alternatively calculate the k_v -values by means of the calculation factor C_A (fig. 18) and the flow rate diagram (in this example: fig. 4) as per the following calculation example.

Calculation example:

Required k_v -value

$$C_A = 0.00132 \text{ (from fig. 18)}$$

$$k_v = C_A \times G$$

$$k_v = 0.00132 \times 2,700 \text{ [kg/h]} \\ = 3.56 \text{ [m}^3\text{/h]}$$

Calculation factor C_A

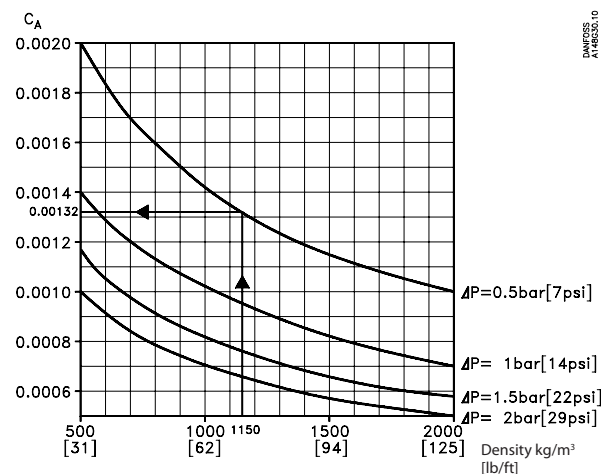

Fig. 18.

Flow rate diagram

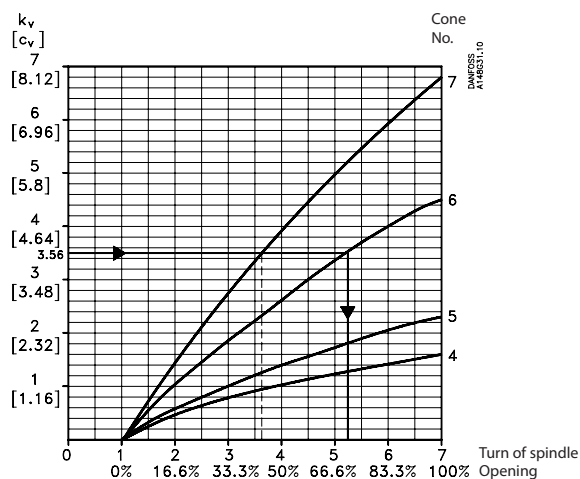
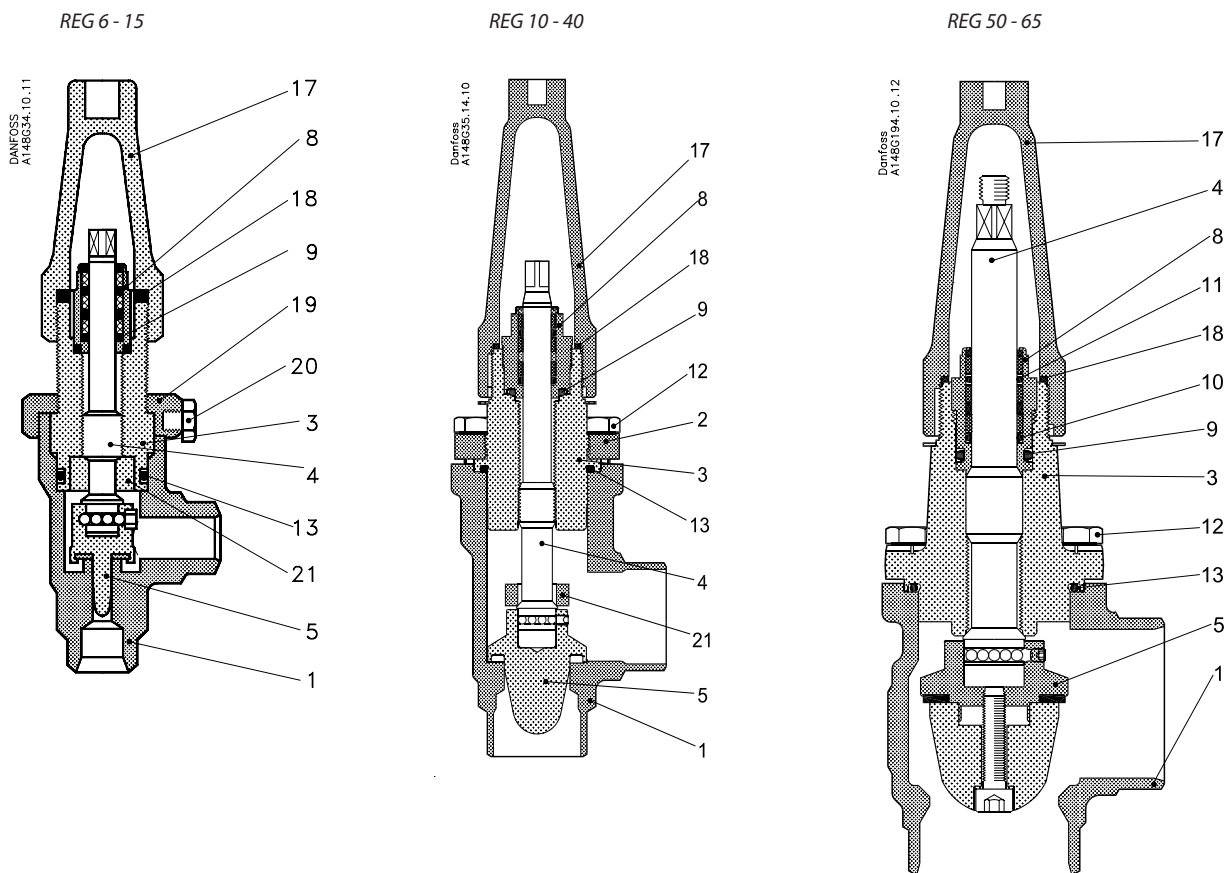

Fig. 4.

Cone no. 6 and 7 can be used. The optimum regulation is obtained if cone number 6 is used.

Material specification



No.	Part	Material	EN	ISO	ASTM
1	Housing	Steel	P285QH EN10222-4		LF2A350
2	DN 10 - 40 (3/8 - 1 1/2 in.) – Bonnet, Flange	Steel	P275 NL EN10028-3		
3	DN 6 - 40 (1/4 - 1 1/2 in.) – Bonnet, Insert DN 50 - 65 (2 - 2 1/2 in.) – Bonnet, Flange	Steel	P285QH EN10222-4		
4	Spindle DN 6 - 40 (1/4 - 1 1/2 in.) DN 50 - 65 (2 - 2 1/2 in.)	Stainless steel Stainless steel	X10CrNiS18-9, 17440 X8CrNiS18-9, 17440	Type 17, 683/13 Type 17, 683/13	AISI 303 AISI 303
5	Cone	Steel			
8	Packing gland	Steel			
9	DN 6 - 20 (1/4 - 3/4 in.) – Packing washer DN 25 - 65 (1 - 2 1/2 in.) – O-ring	Non-asbestos Cloroprene (Neoprene)			
10-11	O-ring	Cloroprene (Neoprene)			
12	Bolts	Stainless steel	A2-70	A2-70	Type 308
13	O-ring	Cloroprene (Neoprene)			
17	Seal cap	Aluminium			
18	Gasket f. seal cap	Nylon			
19	Locking nut	Steel			
20	Screw	Steel			
21	Packing washer	PTFE (Teflon)			

Material specification

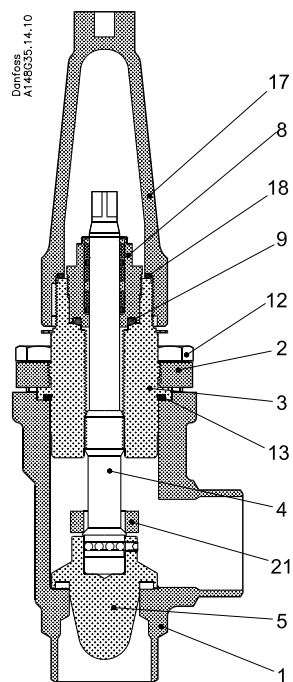

REG-SS 15 - 40 (1/2 - 1 1/2")

No.	Part	Material	DIN/EN	ISO	ASTM
1	Housing	Stainless steel	X5CrNi18-10 EN10088		AISI 304
2	Bonnet, Flange	Stainless steel	X5CrNi18-10 EN10088		AISI 304
3	Bonnet, Insert	Stainless steel			
4	Spindle	Stainless steel	X8CrNiS18-9 DIN 17440	Type 17, 683/13	AISI 303
5	Cone	Steel			
8	Packing gland	Stainless steel			
9	Packing washer	Non-asbestos			
12	Bolts	Stainless steel	A2-70	A2-70	Type 308
13	O-ring	Cloroprene (Neoprene)			
17	Spindle seal cap	Aluminium			
18	Seal cap gasket	Nylon			
19	Locking nut	Steel			
20	Screw	Steel			
21	Packing washer	PTFE (Teflon)			

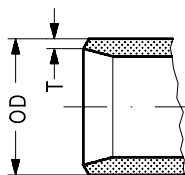
Regulating valves, types REG 6 - 65 and REG-SS 15-40
Connections
DIN

	Size mm	Size in.	OD mm	T mm	OD in.	T in.		Cone no.
<i>Welding DIN (EN 10220)</i>								
Small	6	1/4	13.5	2.3	0.531	0.091		① ② ③
	10	3/8	17.2	2.3	0.677	0.091		
Medium	15	1/2	21.3	2.3	0.839	0.091		④ ⑤ ⑥ ⑦
	20	3/4	26.9	2.3	1.059	0.091		
	25	1	33.7	2.6	1.327	0.103		
Large	32	1 1/4	42.4	2.6	1.669	0.102		⑧ ⑨ ⑩
	40	1 1/2	48.3	2.6	1.902	0.103		
	50	2	60.3	2.9	2.37	0.11		⑪
	65	2 1/2	76.1	2.9	3	0.11		⑫

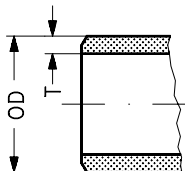
ANSI

	Size mm	Size in.	ID mm	T mm	ID in.	T in.	L mm	L in.	Cone no.
<i>Welding ANSI (B 36.10 Schedule 80)</i>									
Small	6	1/4	13.5	3.0	0.531	0.118			① ② ③
	10	3/8	17.2	3.2	0.677	0.126			
Medium	15	1/2	21.3	3.7	0.839	0.146			④ ⑤ ⑥ ⑦
	20	3/4	26.9	4.0	1.059	0.158			
	25	1	33.7	4.6	1.327	0.181			
Large	32	1 1/4	42.4	4.9	1.669	0.193			⑧ ⑨ ⑩
	40	1 1/2	48.3	5.1	1.902	0.201			
<i>Welding ANSI (B 36.10 Schedule 40)</i>									
	50	2	60.3	3.9	2.37	0.15			⑪
	65	2 1/2	73.0	5.2	2.87	0.20			⑫

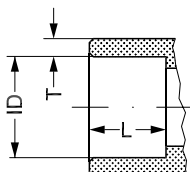
SOC

	Size mm	Size in.	ID mm	T mm	ID in.	T in.	L mm	L in.	Cone no.
<i>Socket welding ANSI (B 16.11)</i>									
Medium	15	1/2	21.8	6.0	0.858	0.235	10	0.39	④ ⑤ ⑥ ⑦
	20	3/4	27.2	7.6	1.071	0.299	13	0.51	
Large	25	1	33.9	7.2	1.335	0.284	13	0.51	⑧ ⑨ ⑩
	32	1 1/4	42.7	6.1	1.743	0.240	13	0.51	
	40	1 1/2	48.8	6.6	1.921	0.260	13	0.51	

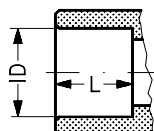
SA

	Size mm	Size in.	ID mm	T mm	ID in.	T in.	L mm	L in.	Cone no.
<i>Soldering (ANSI B 16.22)</i>									
Small	10	3/8	9.60		0.378		8	0.31	① ② ③
	15	1/2	12.75		0.502		10	0.39	
Medium	22	7/8	22.30		0.878		19	0.75	④ ⑤ ⑥ ⑦

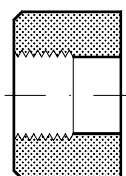
FPT

	Size mm	Size in.	Inside pipe thread		Cone no.
<i>FPT inside pipe thread, NPT (ANSI/ASME B 1.20.1)</i>					
Mellem	15	1/2	(1/2 x 14 NPT)		④ ⑤ ⑥ ⑦
	20	3/4	(3/4 x 14 NPT)		
Large	25	1	(1 x 11.5 NPT)		⑧ ⑨ ⑩
	32	1 1/4	(1 1/4 x 11.5 NPT)		

Regulating valves, types REG 6 - 65 and REG-SS 15-40

Dimensions and weights

REG 6 - 40 in angleway version

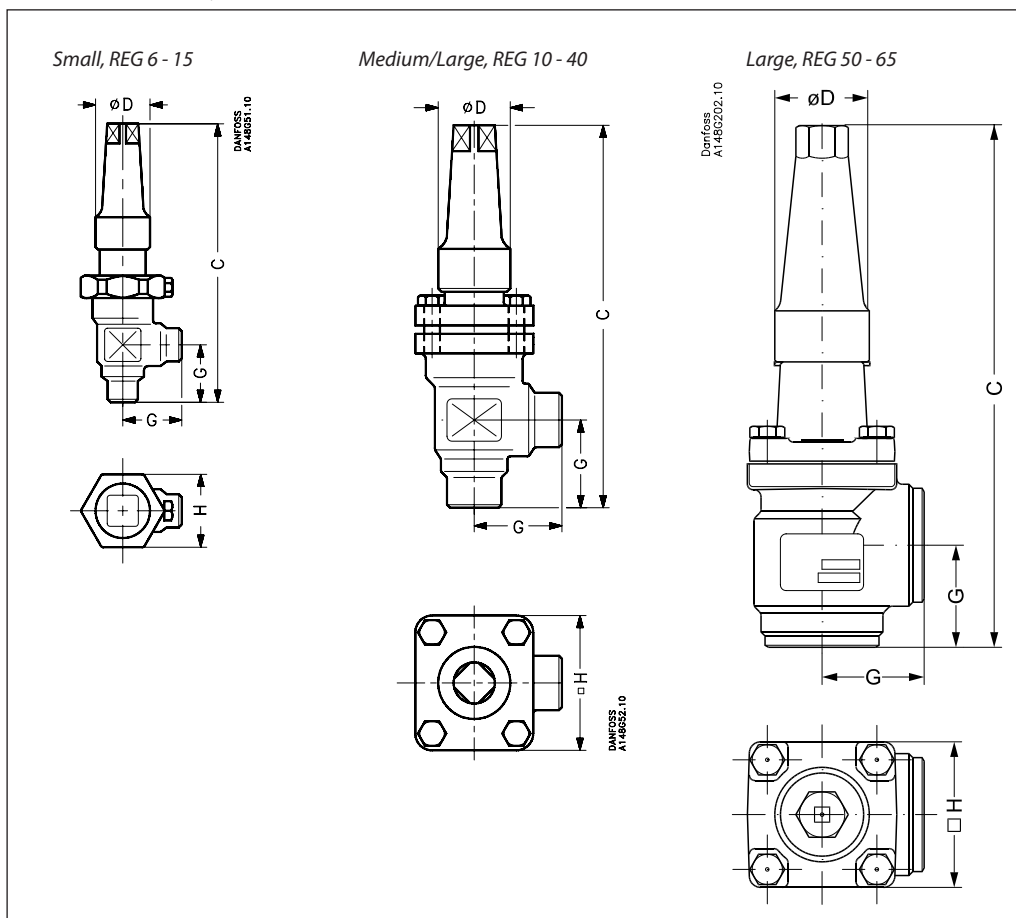

Valve size		C	G	$\varnothing D$	$\square H$	Weight
Small valve housing	mm	139	30	30	36	0.8 kg
	in.	5.47	1.18	1.18	1.42	1.8 lb
Medium valve housing	mm	182	45	38	60	1.4 kg
	in.	7.17	1.77	1.50	2.36	3.1 lb
Large valve housing	mm	237	55	50	70	2.4 kg
	in.	9.33	2.17	1.97	2.76	5.3 lb
REG 50	mm	280	60	50	77	3.2 kg
REG (2 in.)	in.	11.02	2.36	1.97	3.03	7.1 lb
REG 65	mm	305	70	50	90	4.8 kg
REG (2½ in.)	in.	12.01	2.76	1.97	3.54	10.6 lb
REG 32 SOC	mm	275	62	50	70	2.9 kg
REG (1¼ in.) SOC	in.	10.83	2.44	1.97	2.76	6.4 lb
REG 40 SOC	mm	275	62	50	70	2.9 kg
REG (1½ in.) SOC	in.	10.83	2.44	1.97	2.76	6.4 lb

Specified weights are approximate values only.

Regulating valves, types REG 6 - 65 and REG-SS 15-40

**Dimensions and weights
(cont.)**

REG 6 - 40 in straight way version

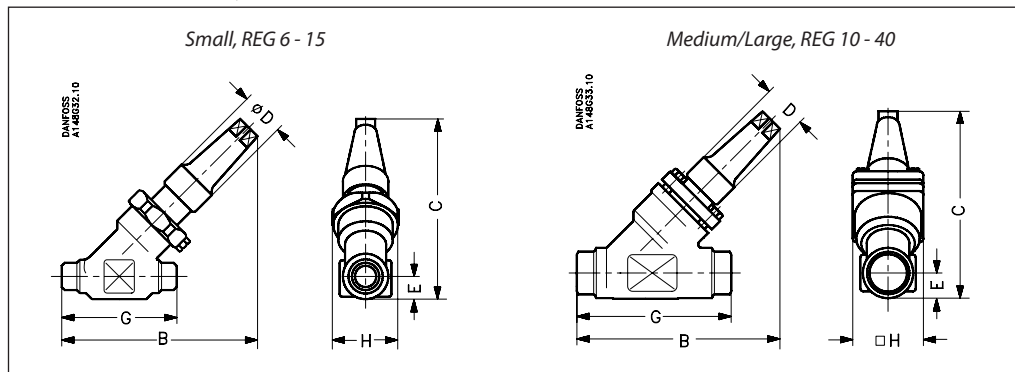

Valve size		C	B	E	G	ØD		□H		Weight
Small valve housing	mm	110	120	13	70	30		36		0.8 kg
	in.	4.33	4.72	0.51	2.76	1.18		1.42		1.8 lb
Medium valve housing	mm	145	155	20	120	38		60		2.0 kg
	in.	5.71	6.10	0.79	4.72	1.50		2.36		4.4 lb
Large valve housing	mm	200	215	26	155	50		70		3.0 kg
	in.	7.87	8.46	1.02	6.10	1.97		2.76		6.6 lb
REG 32 SOC	mm	209	222	27.4	155	50		70		3.0 kg
REG (1¼) SOC	in.	8.23	8.74	1.08	6.10	1.97		2.76		6.6 lb
REG 40 SOC	mm	213	222	31.0	155	50		70		3.0 kg
REG (1½) SOC	in.	8.39	8.74	1.22	6.10	1.97		2.76		6.6 lb

Specified weights are approximate values only.

Regulating valves, types REG 6 - 65 and REG-SS 15-40

Ordering

How to order

The table below is used to identify the valve required.

Please note that the type codes only serve to identify the valves some of which may not form part of the standard product range. For further information please contact your local Danfoss Sales Company.

Type codes

Valve type	REG	Regulating Valves																																																												
Nominal size in mm (Valve size measured on the connection diameter)	6 10 15 20 22 25 32 40 50 65	<table border="1"> <thead> <tr> <th colspan="5">Available connections</th> </tr> <tr> <th>A</th> <th>D</th> <th>SOC</th> <th>SA</th> <th>FPT</th> </tr> </thead> <tbody> <tr> <td>DN 6</td> <td>x</td> <td>x</td> <td></td> <td></td> </tr> <tr> <td>DN 10</td> <td>x</td> <td>x</td> <td></td> <td>x</td> </tr> <tr> <td>DN 15</td> <td>x</td> <td>x</td> <td>x</td> <td>x</td> </tr> <tr> <td>DN 20</td> <td>x</td> <td>x</td> <td>x</td> <td>x</td> </tr> <tr> <td>DN 22</td> <td></td> <td></td> <td></td> <td>x</td> </tr> <tr> <td>DN 25</td> <td>x</td> <td>x</td> <td>x</td> <td>x</td> </tr> <tr> <td>DN 32</td> <td>x</td> <td>x</td> <td>x</td> <td>x</td> </tr> <tr> <td>DN 40</td> <td>x</td> <td>x</td> <td>x</td> <td></td> </tr> <tr> <td>DN 50</td> <td>x</td> <td>x</td> <td></td> <td></td> </tr> <tr> <td>DN 65</td> <td>x</td> <td>x</td> <td></td> <td></td> </tr> </tbody> </table>	Available connections					A	D	SOC	SA	FPT	DN 6	x	x			DN 10	x	x		x	DN 15	x	x	x	x	DN 20	x	x	x	x	DN 22				x	DN 25	x	x	x	x	DN 32	x	x	x	x	DN 40	x	x	x		DN 50	x	x			DN 65	x	x		
		Available connections																																																												
		A	D	SOC	SA	FPT																																																								
		DN 6	x	x																																																										
		DN 10	x	x		x																																																								
		DN 15	x	x	x	x																																																								
		DN 20	x	x	x	x																																																								
		DN 22				x																																																								
		DN 25	x	x	x	x																																																								
		DN 32	x	x	x	x																																																								
		DN 40	x	x	x																																																									
		DN 50	x	x																																																										
DN 65	x	x																																																												
Connections	A	Welding branches: ANSI B 36.10 schedule 80, 15 - 40 (½ - 1½ in.) Welding branches: ANSI B 36.10 schedule 40, 50 - 65 (2 - 2½ in.)																																																												
	D	Welding branches: DIN 2448																																																												
	SOC	Socket weld: ANSI B 16.11																																																												
	SA	Soldering branches: ANSI B 16.22																																																												
	FPT	NPT inside pipe thread: ANSI/ASME B1.20.1																																																												
Valve housing	ANG	Angle flow																																																												
	STR	Straight flow																																																												
Cone	Cone#	Flow area [mm ²]																																																												
	1	3																																																												
	2	6																																																												
	3	12																																																												
	4	28																																																												
	5	44																																																												
	6	92																																																												
	7	152																																																												
	8	272																																																												
	9	432																																																												
	10	648																																																												
	11	822																																																												
12	1978																																																													

Verification of the combination between cone no. and valve connection

Valve size	Small valve	Medium valve	Large valve	REG 50	REG 65
Cone no.	① ② ③	④ ⑤ ⑥ ⑦	⑧ ⑨ ⑩	⑪	⑫

DIN	DN 6, 10, 15*	DN 15, 20, 25	DN 32, 40	DN 50	DN 65
ANSI	DN 6, 10	DN 15, 20, 25	DN 32, 40	DN 50	DN 65
SOC		DN 15, 20	DN 25, 32, 40		
SA	DN 10, 15	DN 22			
FPT		DN 15, 20	DN 25, 32		

*Small valve size 15 DIN is only available with cone number 3.

Regulating valves, types REG 6 - 65 and REG-SS 15-40
Ordering
(continued)

Example:
 REG 15 DIN angleway with cone
 no. 7 = **148G3242**

Important!
 Where products need to be certified according to specific certification societies or where higher pressures are required, the relevant information should be included at the time of order.

Angleway

Size		Type	Code no.
mm	in.		

DIN

6	1/4	REG 6 D ANG CONE#1	2415+426
6	1/4	REG 6 D ANG CONE#2	2415+427
6	1/4	REG 6 D ANG CONE#3	2415+428
10	3/8	REG 10 D ANG CONE#1	2415+432
10	3/8	REG 10 D ANG CONE#2	2415+433
10	3/8	REG 10 D ANG CONE#3	2415+434
15	1/2	REG 15 D ANG CONE#3	2415+883
15	1/2	REG 15 D ANG CONE#4	148G3239
15	1/2	REG-SS 15 D ANG CONE#4 52BAR	148G3542
15	1/2	REG 15 D ANG CONE#5	148G3240
15	1/2	REG-SS 15 D ANG CONE#5 52BAR	148G3543
15	1/2	REG 15 D ANG CONE#6	148G3241
15	1/2	REG-SS 15 D ANG CONE#6 52BAR	148G3544
15	1/2	REG 15 D ANG CONE#7	148G3242
15	1/2	REG-SS 15 D ANG CONE#7 52BAR	148G3545
20	3/4	REG 20 D ANG CONE#4	148G3247
20	3/4	REG-SS 20 D ANG CONE#4 52BAR	148G3546
20	3/4	REG 20 D ANG CONE#5	148G3248
20	3/4	REG-SS 20 D ANG CONE#5 52BAR	148G3547
20	3/4	REG 20 D ANG CONE#6	148G3249
20	3/4	REG-SS 20 D ANG CONE#6 52BAR	148G3548
20	3/4	REG 20 D ANG CONE#7	148G3250
20	3/4	REG-SS 20 D ANG CONE#7 52BAR	148G3549
25	1	REG 25 D ANG CONE#4	148G3255
25	1	REG-SS 25 D ANG CONE#4 52BAR	148G3550
25	1	REG 25 D ANG CONE#5	148G3256
25	1	REG-SS 25 D ANG CONE#5 52BAR	148G3551
25	1	REG 25 D ANG CONE#6	148G3257
25	1	REG-SS 25 D ANG CONE#6 52BAR	148G3552
25	1	REG 25 D ANG CONE#7	148G3258
25	1	REG-SS 25 D ANG CONE#7 52BAR	148G3553
32	1 1/4	REG 32 D ANG CONE#8	148G3263
32	1 1/4	REG-SS 32 D ANG CONE#8 52BAR	148G3555
32	1 1/4	REG 32 D ANG CONE#9	148G3264
32	1 1/4	REG-SS 32 D ANG CONE#9 52BAR	148G3556
32	1 1/4	REG 32 D ANG CONE#10	148G3265
32	1 1/4	REG-SS 32 D ANG CONE#10 52BAR	148G3554
40	1 1/2	REG 40 D ANG CONE#8	148G3269
40	1 1/2	REG-SS 40 D ANG CONE#8 52BAR	148G3558
40	1 1/2	REG 40 D ANG CONE#9	148G3270
40	1 1/2	REG-SS 40 D ANG CONE#9 52BAR	148G3559
40	1 1/2	REG 40 D ANG CONE#10	148G3271
40	1 1/2	REG-SS 40 D ANG CONE#10 52BAR	148G3557
50	2	REG 50 D ANG CONE#11	148G3485
65	2 1/2	REG 65 D ANG CONE#12	148G3486

D = Butt-weld DIN
 A = Butt-weld ANSI
 SOC = Socket weld
 SA = Soldering
 FPT = Inside pipe thread

ANG = Angleway
 STR = Straightway

Regulating valves, types REG 6 - 65 and REG-SS 15-40
Ordering
(continued)
Angleway

Size		Type	Code no.
mm	in.		

ANSI

6	1/4	REG 6 A ANG CONE#1	2415+474
6	1/4	REG 6 A ANG CONE#2	2415+475
6	1/4	REG 6 A ANG CONE#3	2415+476
10	3/8	REG 10 A ANG CONE#1	2415+480
10	3/8	REG 10 A ANG CONE#2	2415+481
10	3/8	REG 10 A ANG CONE#3	2415+482
15	1/2	REG 15 A ANG CONE#4	148G3276
15	1/2	REG 15 A ANG CONE#5	148G3277
15	1/2	REG 15 A ANG CONE#6	148G3278
15	1/2	REG 15 A ANG CONE#7	148G3279
20	3/4	REG 20 A ANG CONE#4	148G3284
20	3/4	REG 20 A ANG CONE#5	148G3285
20	3/4	REG 20 A ANG CONE#6	148G3286
20	3/4	REG 20 A ANG CONE#7	148G3287
25	1	REG 25 A ANG CONE#4	148G3292
25	1	REG 25 A ANG CONE#5	148G3293
25	1	REG 25 A ANG CONE#6	148G3294
25	1	REG 25 A ANG CONE#7	148G3295
32	1 1/4	REG 32 A ANG CONE#8	148G3300
32	1 1/4	REG 32 A ANG CONE#9	148G3301
32	1 1/4	REG 32 A ANG CONE#10	148G3302
40	1 1/2	REG 40 A ANG CONE#8	148G3306
40	1 1/2	REG 40 A ANG CONE#9	148G3307
40	1 1/2	REG 40 A ANG CONE#10	148G3308
50	2	REG 50 A ANG CONE#11	148G3487
65	2 1/2	REG 65 A ANG CONE#12	148G3488

SOC

15	1/2	REG 15 SOC ANG CONE#4	148G3312
15	1/2	REG 15 SOC ANG CONE#5	148G3313
15	1/2	REG 15 SOC ANG CONE#6	148G3314
15	1/2	REG 15 SOC ANG CONE#7	148G3315
20	3/4	REG 20 SOC ANG CONE#4	148G3322
20	3/4	REG 20 SOC ANG CONE#5	148G3323
20	3/4	REG 20 SOC ANG CONE#6	148G3324
20	3/4	REG 20 SOC ANG CONE#7	148G3325
25	1	REG 25 SOC ANG CONE#8	148G3330
25	1	REG 25 SOC ANG CONE#9	148G3331
25	1	REG 25 SOC ANG CONE#10	148G3332
32	1 1/4	REG 32 SOC ANG CONE#8	148G3336
32	1 1/4	REG 32 SOC ANG CONE#9	148G3337
32	1 1/4	REG 32 SOC ANG CONE#10	148G3338
40	1 1/2	REG 40 SOC ANG CONE#8	148G3342
40	1 1/2	REG 40 SOC ANG CONE#9	148G3343
40	1 1/2	REG 40 SOC ANG CONE#10	148G3417

FPT

15	1/2	REG 15 FPT ANG CONE#4	148G3389
15	1/2	REG 15 FPT ANG CONE#5	148G3390
15	1/2	REG 15 FPT ANG CONE#6	148G3391
15	1/2	REG 15 FPT ANG CONE#7	148G3392
20	3/4	REG 20 FPT ANG CONE#4	148G3397
20	3/4	REG 20 FPT ANG CONE#5	148G3398
20	3/4	REG 20 FPT ANG CONE#6	148G3399
20	3/4	REG 20 FPT ANG CONE#7	148G3400
25	1	REG 25 FPT ANG CONE#8	148G3405
25	1	REG 25 FPT ANG CONE#9	148G3406
25	1	REG 25 FPT ANG CONE#10	148G3407
32	1 1/4	REG 32 FPT ANG CONE#8	148G3411
32	1 1/4	REG 32 FPT ANG CONE#9	148G3412

- D = Butt-weld DIN
 A = Butt-weld ANSI
 SOC = Socket weld
 SA = Soldering
 FPT = Inside pipe thread

 ANG = Angleway
 STR = Straightway

Regulating valves, types REG 6 - 65 and REG-SS 15-40
Ordering
(continued)
Angleway

Size		Type	Code no.
mm	in.		

SA

10	$\frac{3}{8}$	REG 10 SA ANG CONE#1 CU: 3/8"	2415+559
10	$\frac{3}{8}$	REG 10 SA ANG CONE#2 CU: 3/8"	2415+560
10	$\frac{3}{8}$	REG 10 SA ANG CONE#3 CU: 3/8"	2415+561
15	$\frac{1}{2}$	REG 15 SA ANG CONE#1 CU: 1/2"	2415+565
15	$\frac{1}{2}$	REG 15 SA ANG CONE#2 CU: 1/2"	2415+566
15	$\frac{1}{2}$	REG 15 SA ANG CONE#3 CU: 1/2"	2415+567
22	$\frac{7}{8}$	REG 22 SA ANG CONE#4 CU: 7/8"	148G3363
22	$\frac{7}{8}$	REG 22 SA ANG CONE#5 CU: 7/8"	148G3364
22	$\frac{7}{8}$	REG 22 SA ANG CONE#6 CU: 7/8"	148G3365
22	$\frac{7}{8}$	REG 22 SA ANG CONE#7 CU: 7/8"	148G3366

- D = Butt-weld DIN
- A = Butt-weld ANSI
- SOC = Socket weld
- SA = Soldering
- FPT = Inside pipe thread

- ANG = Angleway
- STR = Straightway

Regulating valves, types REG 6 - 65 and REG-SS 15-40
Ordering
(continued)
Straightway

Size		Type	Code no.
mm	in.		

DIN

6	1/4	REG 6 D STR CONE#1	2415+429
6	1/4	REG 6 D STR CONE#2	2415+430
6	1/4	REG 6 D STR CONE#3	2415+431
10	3/8	REG 10 D STR CONE#1	2415+435
10	3/8	REG 10 D STR CONE#2	2415+436
10	3/8	REG 10 D STR CONE#3	2415+437
15	1/2	REG 15 D STR CONE#4	148G3243
15	1/2	REG-SS 15 D STR CONG#4 52BAR	148G3640
15	1/2	REG 15 D STR CONE#5	148G3244
15	1/2	REG-SS 15 D STR CONG#5 52BAR	148G3641
15	1/2	REG 15 D STR CONE#6	148G3245
15	1/2	REG-SS 15 D STR CONG#6 52BAR	148G3642
15	1/2	REG 15 D STR CONE#7	148G3246
15	1/2	REG-SS 15 D STR CONG#7 52BAR	148G3643
20	3/4	REG 20 D STR CONE#4	148G3251
20	3/4	REG-SS 20 D STR CONG#4 52BAR	148G3644
20	3/4	REG 20 D STR CONE#5	148G3252
20	3/4	REG-SS 20 D STR CONG#5 52BAR	148G3645
20	3/4	REG 20 D STR CONE#6	148G3253
20	3/4	REG-SS 20 D STR CONG#6 52BAR	148G3646
20	3/4	REG 20 D STR CONE#7	148G3254
20	3/4	REG-SS 20 D STR CONG#7 52BAR	148G3647
25	1	REG 25 D STR CONE#4	148G3259
25	1	REG-SS 25 D STR CONG#4 52BAR	148G3648
25	1	REG 25 D STR CONE#5	148G3260
25	1	REG-SS 25 D STR CONG#5 52BAR	148G3649
25	1	REG 25 D STR CONE#6	148G3261
25	1	REG-SS 25 D STR CONG#6 52BAR	148G3650
25	1	REG 25 D STR CONE#7	148G3262
25	1	REG-SS 25 D STR CONG#7 52BAR	148G3651
32	1 1/4	REG 32 D STR CONE#8	148G3266
32	1 1/4	REG-SS 32 D STR CONG#8 52BAR	148G3653
32	1 1/4	REG 32 D STR CONE#9	148G3267
32	1 1/4	REG-SS 32 D STR CONG#9 52BAR	148G3654
32	1 1/4	REG 32 D STR CONE#10	148G3268
32	1 1/4	REG-SS 32 D STR CONG#10 52BAR	148G3652
40	1 1/2	REG 40 D STR CONE#8	148G3273
40	1 1/2	REG-SS 40 D STR CONG#8 52BAR	148G3656
40	1 1/2	REG 40 D STR CONE#9	148G3274
40	1 1/2	REG-SS 40 D STR CONG#9 52BAR	148G3657
40	1 1/2	REG 40 D STR CONE#10	148G3275
40	1 1/2	REG-SS 40 D STR CONG#10 52BAR	148G3655

- D = Butt-weld DIN
 A = Butt-weld ANSI
 SOC = Socket weld
 SA = Soldering
 FPT = Inside pipe thread

 ANG = Angleway
 STR = Straightway

Regulating valves, types REG 6 - 65 and REG-SS 15-40
Ordering
(continued)
Straightway

Size		Type	Code no.
mm	in.		

ANSI

6	1/4	REG 6 A STR CONE#1	2415+477
6	1/4	REG 6 A STR CONE#2	2415+478
6	1/4	REG 6 A STR CONE#3	2415+479
10	3/8	REG 10 A STR CONE#1	2415+483
10	3/8	REG 10 A STR CONE#2	2415+484
10	3/8	REG 10 A STR CONE#3	2415+485
15	1/2	REG 15 A STR CONE#4	148G3280
15	1/2	REG 15 A STR CONE#5	148G3281
15	1/2	REG 15 A STR CONE#6	148G3282
15	1/2	REG 15 A STR CONE#7	148G3283
20	3/4	REG 20 A STR CONE#4	148G3288
20	3/4	REG 20 A STR CONE#5	148G3289
20	3/4	REG 20 A STR CONE#6	148G3290
20	3/4	REG 20 A STR CONE#7	148G3291
25	1	REG 25 A STR CONE#4	148G3296
25	1	REG 25 A STR CONE#5	148G3297
25	1	REG 25 A STR CONE#6	148G3298
25	1	REG 25 A STR CONE#7	148G3299
32	1 1/4	REG 32 A STR CONE#8	148G3303
32	1 1/4	REG 32 A STR CONE#9	148G3304
32	1 1/4	REG 32 A STR CONE#10	148G3305
40	1 1/2	REG 40 A STR CONE#8	148G3309
40	1 1/2	REG 40 A STR CONE#9	148G3310
40	1 1/2	REG 40 A STR CONE#10	148G3311

SOC

15	1/2	REG 15 SOC STR CONE#4	148G3316
15	1/2	REG 15 SOC STR CONE#5	148G3317
15	1/2	REG 15 SOC STR CONE#6	148G3318
15	1/2	REG 15 SOC STR CONE#7	148G3319
20	3/4	REG 20 SOC STR CONE#4	148G3326
20	3/4	REG 20 SOC STR CONE#5	148G3327
20	3/4	REG 20 SOC STR CONE#6	148G3328
20	3/4	REG 20 SOC STR CONE#7	148G3329
25	1	REG 25 SOC STR CONE#8	148G3333
25	1	REG 25 SOC STR CONE#9	148G3334
25	1	REG 25 SOC STR CONE#10	148G3335
32	1 1/4	REG 32 SOC STR CONE#8	148G3339
32	1 1/4	REG 32 SOC STR CONE#9	148G3340
32	1 1/4	REG 32 SOC STR CONE#10	148G3341
40	1 1/2	REG 40 SOC STR CONE#8	148G3344
40	1 1/2	REG 40 SOC STR CONE#9	148G3345
40	1 1/2	REG 40 SOC STR CONE#10	148G3346

FPT

15	1/2	REG 15 FPT STR CONE#4	148G3393
15	1/2	REG 15 FPT STR CONE#5	148G3394
15	1/2	REG 15 FPT STR CONE#6	148G3395
15	1/2	REG 15 FPT STR CONE#7	148G3396
20	3/4	REG 20 FPT STR CONE#4	148G3401
20	3/4	REG 20 FPT STR CONE#6	148G3403
20	3/4	REG 20 FPT STR CONE#7	148G3404
25	1	REG 25 FPT STR CONE#8	148G3408
25	1	REG 25 FPT STR CONE#9	148G3409
25	1	REG 25 FPT STR CONE#10	148G3410
32	1 1/4	REG 32 FPT STR CONE#8	148G3414
32	1 1/4	REG 32 FPT STR CONE#9	148G3415
32	1 1/4	REG 32 FPT STR CONE#10	148G3416

D = Butt-weld DIN
 A = Butt-weld ANSI
 SOC = Socket weld
 SA = Soldering
 FPT = Inside pipe thread

ANG = Angleway
 STR = Straightway

Regulating valves, types REG 6 - 65 and REG-SS 15-40
Ordering
(continued)
Straightway

Size		Type	Code no.
mm	in.		

SA

10	$\frac{3}{8}$	REG 10 SA STR CONE#1 CU: 3/8"	2415+562
10	$\frac{3}{8}$	REG 10 SA STR CONE#2 CU: 3/8"	2415+563
10	$\frac{3}{8}$	REG 10 SA STR CONE#3 CU: 3/8"	2415+564
15	$\frac{1}{2}$	REG 15 SA STR CONE#1 CU: 1/2"	2415+568
15	$\frac{1}{2}$	REG 15 SA STR CONE#2 CU: 1/2"	2415+569
15	$\frac{1}{2}$	REG 15 SA STR CONE#3 CU: 1/2"	2415+570
22	$\frac{7}{8}$	REG 22 SA STR CONE#4 CU: 7/8"	148G3367
22	$\frac{7}{8}$	REG 22 SA STR CONE#5 CU: 7/8"	148G3368
22	$\frac{7}{8}$	REG 22 SA STR CONE#6 CU: 7/8"	148G3369
22	$\frac{7}{8}$	REG 22 SA STR CONE#7 CU: 7/8"	148G3370

D = Butt-weld DIN
 A = Butt-weld ANSI
 SOC = Socket weld
 SA = Soldering
 FPT = Inside pipe thread

ANG = Angleway
 STR = Straightway

